

COOL BOXES

MCF 40, MCF 60

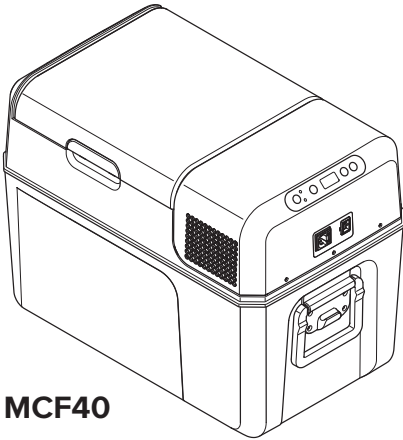

MCF40

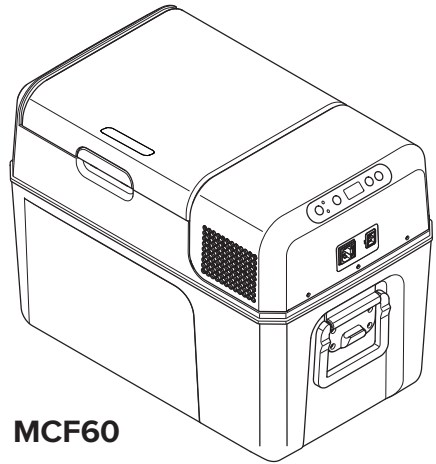

MCF60

EN

Compressor cooler
Operating manual

Please read this manual carefully before starting the device. Keep it in a safe place for future reference. If the device is passed on to another person, this manual must be handed over to the user along with it.

The manufacturer cannot be held liable for damage resulting from **improper usage** or **incorrect operation**.

Contents

1	Explanation of symbols	4
2	Safety instructions	4
2.1	General safety	4
2.2	Operating the device safely	6
3	Scope of delivery	6
4	Intended use	7
5	Function description	7
5.1	Scope of functions	7
5.2	Operating and display elements	8
6	Operation	10
6.1	Before initial use	10
6.2	Energy saving tips	10
6.3	Connecting the cooling device	11
6.4	Using the battery monitor	11
6.5	Using the cooling device	12
6.6	Latching the cooling device lid	13
6.7	Setting the temperature	13
6.8	Switching off the cooling device	14
6.9	Interior light control (MCF60 only)	14
6.10	Defrosting the cooling device	15
6.11	Replacing the AC fuse	15
6.12	Replacing the DC fuse	16

7	Cleaning and maintenance	16
8	Warranty	17
9	Troubleshooting	17
10	Disposal	18
11	Technical data	19

1 Explanation of symbols

**WARNING!**

Safety instruction: Failure to observe this instruction can cause death or serious injury.

**CAUTION!**

Safety instruction: Failure to observe this instruction can lead to injury.

**NOTICE!**

Failure to observe this instruction can cause material damage and impair the function of the product.

**NOTE**

Supplementary information for operating the product.

2 Safety instructions

2.1 General safety

**WARNING!**

- Do not operate the device if it is visibly damaged.
- If this device's power cable is damaged, it must be replaced by the manufacturer, customer service or a similarly qualified person in order to prevent safety hazards.
- This device may only be repaired by qualified personnel. Improper repairs can lead to considerable hazards.

- This device can be used by children aged 8 years or over, as well as by persons with diminished physical, sensory or mental capacities or a lack of experience and/or knowledge, providing they are supervised or have been taught how to use the device safely and are aware of the resulting risks.
- Cleaning and user maintenance must not be carried out by children without supervision.
- Children must not play with the device.
- Children must be supervised to ensure that they do not play with the device.
- Always keep and use the device out of the reach of children under the age of 8 years.
- Do not store any explosive substances such as spray cans with a flammable propellant in the device.

**CAUTION!**

- Disconnect the device from the power supply
 - before each cleaning and maintenance
 - after every use
- Food may only be stored in its original packaging or in suitable containers.

**NOTICE!**

- Check that the voltage specification on the type plate corresponds to that of the energy supply.
- Only connect the device as follows:
 - With the DC cable to a DC plug socket in the vehicle (e. g. cigarette lighter)
 - Or with the 230 V connection cable to the 230 V AC mains supply
- Never pull the plug out of the socket by the cable.
- If the cooler is connected to the DC socket: Disconnect the cooler and other power consuming devices from the battery before connecting the quick charging device.
- If the cooler is connected to the DC socket: Ensure the battery monitor is set to a suitable mode. Otherwise you may discharge the battery.
- The cooling device is not suitable for transporting caustic materials or materials containing solvents.

- The cooling device contains inflammable cyclopentane in the insulation. The gases in the insulation material require special disposal procedures. Deliver the device at the end of its life-cycle to an appropriate recycling.

2.2 Operating the device safely



CAUTION!

- Before starting the device, ensure that the power supply line and the plug are dry.



NOTICE!

- Do not use electrical devices inside the cooler unless they are recommended by the manufacturer for the purpose.
- Do not place the device near naked flames or other heat sources (heaters, direct sunlight, gas ovens etc.).
- **Danger of overheating!**
Ensure at all times that there is sufficient ventilation so that the heat that arises during operation does not build up. Make sure that the device is sufficiently far away from walls and other objects so that the air can circulate.
- Ensure that the ventilation openings are not covered.
- Do not fill the inner container with ice or fluid.
- Never immerse the device in water.
- Protect the device and the cables against heat and moisture.
- Protect the device from exposure to rain.

3 Scope of delivery

Quantity	Description
1	Compressor cooler
1	DC connection cable
1	AC connection cable
1	Operating manual

4 Intended use

The cooling device is suitable for cooling and freezing foods. The cooling device is also suitable for camping use and in mobile applications such as vehicles, caravans or boats.

The cooling device is designed to be operated from a DC power supply socket of a vehicle, boat or caravan or from an AC mains.



CAUTION! Health hazard!

Please check if the cooling capacity of the cooling device is suitable for storing the food or medicine you wish to cool.

5 Function description

The cooling device can chill products, keep them cool as well as freeze them. A low maintenance refrigerant circuit with compressor provides the cooling. The foamed in place insulation and compact compressor ensure optimum cooling.

The cooling device is portable.

The cooler can withstand a short-term inclination of 30°, for example on boats.

5.1 Scope of functions

- Three-level battery monitor to protect the vehicle battery
- Display with temperature gauge
switches off automatically at low battery voltage
- Temperature setting: With two buttons in steps of 1 °C (2 °F)

5.2 Operating and display elements

Latch for lid (1)

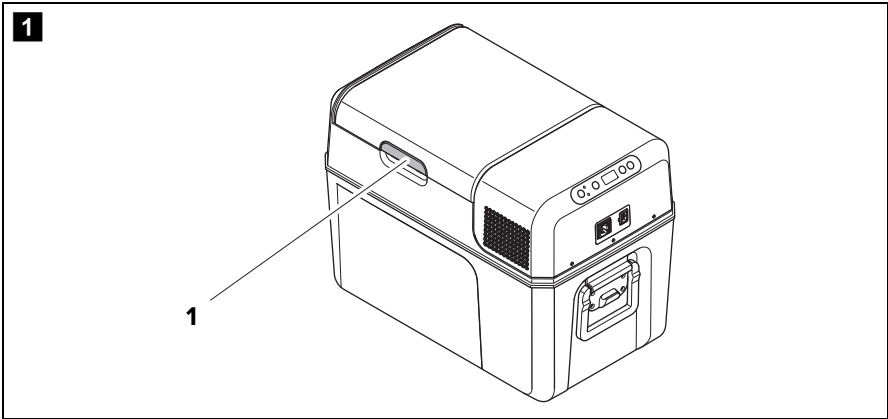

Operating panel

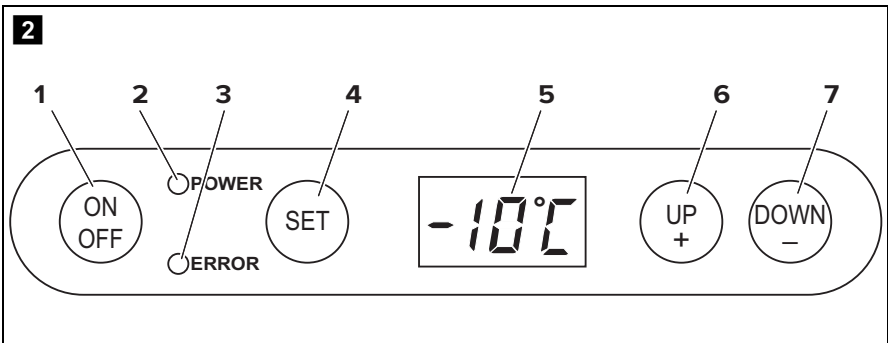

Item	Description	Explanation
1	ON OFF	Switches the cooling device on or off when the button is pressed for between one and two seconds
2	POWER	Status indication LED lights up green: Compressor is on LED lights up orange: Compressor is off LED flashes orange: Display switched off automatically due to low battery voltage

Item	Description	Explanation
3	ERROR	LED flashes red: Cooling device is switched on but not ready for operation
4	SET	Selects the input mode – Temperature setting – Celsius or Fahrenheit display – Set battery monitor
5	–	Display, shows the information
6	“+”	Press once to increase the value
7	“–”	Press once to decrease the value

Connectors

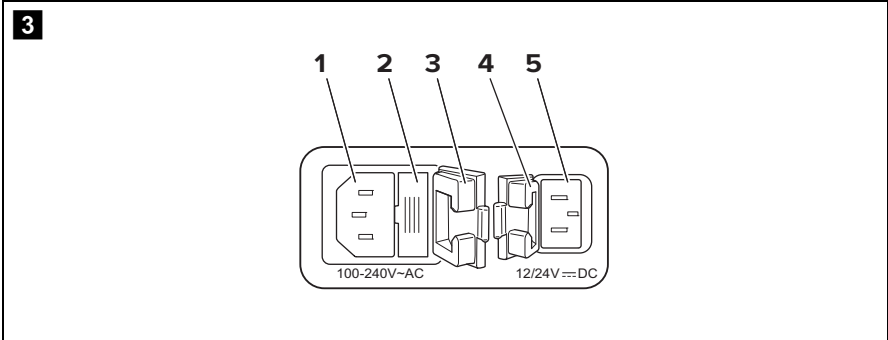

Item	Description
1	AC socket
2	AC Fuse holder
3	Cover AC socket
4	Cover DC socket
5	DC socket

6 Operation

6.1 Before initial use

**NOTE**

Before starting your new cooling device for the first time, you should clean it inside and outside with a damp cloth for hygienic reasons (please also refer to the chapter “Cleaning and maintenance” on page 16).

Selecting the temperature units

You can switch the temperature display between Celsius and Fahrenheit. Proceed as follows:

- Switch on the cooling device.
- Press the “SET” button twice.
- Use the “+” and “-” buttons to select Celsius or Fahrenheit.
- ✓ The selected temperature units then appear in the display for a few seconds. The display flashes several times before it returns to the current temperature.

6.2 Energy saving tips

- Choose a well ventilated location which is protected from direct sunlight.
- Allow warm food to cool down first before placing it in the cooling device to keep cool.
- Do not open the cooling device more often than necessary.
- Do not leave the cooling device open for longer than necessary.
- Defrost the cooling device once a layer of ice forms.
- Avoid unnecessarily low temperatures.

6.3 Connecting the cooling device

The cooling device can be operated with DC or AC voltage.



NOTICE! Danger of damage!

- Disconnect the cooling device and other consumer units from the vehicle battery before you connect the vehicle battery to a quick charging device.
Overvoltage can damage the electronics of the cooling device.
- For protection of the cooling device the DC cable supplied includes a fuse inside the plug. Do **not** remove the fused DC plug.
Only use the DC cable supplied.

For safety reasons the cooling device is equipped with an electronic system to prevent polarity reversal. This protects the cooling device against short-circuiting when connecting to a battery.

- Plug the DC connection cable into the DC socket and connect it to a 12 V or 24 V power socket or ...
- ... plug the AC connection cable into the AC voltage socket and connect it to an AC mains.
- Close the covers of the sockets not in use to prevent accidentally touching the sockets. This also prevents dust, water and dirt from entering the socket.

6.4 Using the battery monitor

The cooling device is equipped with a multi-level battery monitor that protects your vehicle battery against excessive discharging when the cooling device is connected to the DC power supply.

If the cooling device is operated when the vehicle ignition is switched off, the cooling device switches off automatically as soon as the supply voltage falls below a set level. The cooling device will switch back on once the vehicle battery has been recharged to the restart voltage level.



NOTICE! Danger of damage!

When switched off by the battery monitor, the vehicle battery will no longer be fully charged. Avoid starting repeatedly or operating current consumers without longer charging phases. Ensure that the vehicle battery is recharged.

In “HIGH” mode, the battery monitor responds faster than at the levels “LOW” and “MED” (see the following table).

Battery monitor mode	LOW	MED	HIGH
Switch-off voltage at 12 V	10.1 V	11.4 V	11.8 V
Restart voltage at 12 V	11.1 V	12.2 V	12.6 V
Switch-off voltage at 24 V	21.5 V	24.1 V	24.6 V
Restart voltage at 24 V	23.0 V	25.3 V	26.2 V

Proceed as follows to select the battery monitor mode:

- ▶ Switch on the cooling device.
- ▶ Press the “SET” button three times.
- ▶ Use the “+” and “-” buttons to select the battery monitor mode.
- ✓ The selected mode then appears in the display for a few seconds. The display flashes several times before it returns to the current temperature.



NOTE

When the cooling device is supplied by the vehicle battery, select the battery monitor mode “HIGH”. If the cooling device is connected to a supply battery, the battery monitor mode “LOW” will suffice.

6.5 Using the cooling device



NOTICE! Danger of overheating!

Ensure at all times that there is sufficient ventilation so that the heat that generated during operation can dissipate. Ensure that the ventilation slots are not covered. Make sure that the cooling device is sufficiently far away from walls and other objects so that the air can circulate.

Proceed as follows:

- ▶ Place the cooling device on a firm foundation.



NOTE

Place the cooling device as shown (fig. **1**, page 8). If you operate the cooling device in a different position it can be damaged.

- Connect the cooling device (chapter “Connecting the cooling device” on page 11).



NOTICE! Danger from excessively low temperature!

Ensure that only those objects are placed in the cooling device that are intended to be cooled at the selected temperature.

- Press the “ON/OFF” button for between one and two seconds.
- ✓ The “POWER” LED lights up.
- ✓ The display switches on and shows the current cooling temperature.



NOTE

The temperature displayed is that of the middle of the interior. The temperatures elsewhere can deviate from this temperature.

- ✓ The cooling device starts cooling the interior.



NOTE

When operating with the battery, the display switches off automatically if the battery voltage is low. The “POWER” LED flashes orange.

6.6 Latching the cooling device lid

- Lift the latch (fig. **1** 1, page 8) and close the lid.
- Release the latch.
- ✓ The latch audibly clicks in place and secures the cooling device lid.

6.7 Setting the temperature

- Press the “SET” button once.
- Use the “+” and “-” buttons to select the cooling temperature.
- ✓ The cooling temperature appears in the display for a few seconds. The display flashes several times and then the current temperature is displayed again.

6.8 Switching off the cooling device

- Empty the cooling device.
- Switch the cooling device off.
- Pull out the connection cable.

If you do not want to use the cooling device for a longer period of time:

- Leave the lid slightly open. This prevents odour build-up.

6.9 Interior light control (MCF60 only)

You can switch the interior light on or off.

Proceed as follows:

- Make sure the display is in normal operation mode, displaying actual temperature.
- Press the “DOWN” button to switch the light on.
- Press the “DOWN” button again to switch the light off.
- The dot (●) in the upper left of display indicates whether the light is on or off.



Interior light ON



Interior light OFF



NOTE

If left on, the interior light switches off automatically after 30 min.

6.10 Defrosting the cooling device

Humidity can form frost in the interior of the cooling device or on the evaporator. This reduces the cooling capacity. Defrost the cooling device in good time to avoid this.



NOTICE! Danger of damage!

Never use hard or pointed tools to remove ice or to loosen objects which have frozen in place.

To defrost the cooling device, proceed as follows:

- Take out the contents of the cooling device.
- If necessary, place them in another cooling device to keep them cool.
- Switch off the cooling device.
- Leave the lid open.
- Wipe off the defrosted water.

6.11 Replacing the AC fuse



DANGER! Danger of electrocution!

Disconnect the connection cable before you replace the AC fuse.

- Remove the connection cable.
- Pry out the fuse holder (fig. **3** 2, page 9) with a screwdriver.
- Replace the defective fuse with a new one that has the same rating (T4AL250V).
- Press back the fuse holder into the housing.

6.12 Replacing the DC fuse



NOTE – Internal DC fuse

There is an additional DC fuse inside the device (Automotive standard blade fuse, 10 A). This fuse can only be replaced by an authorised repair centre.

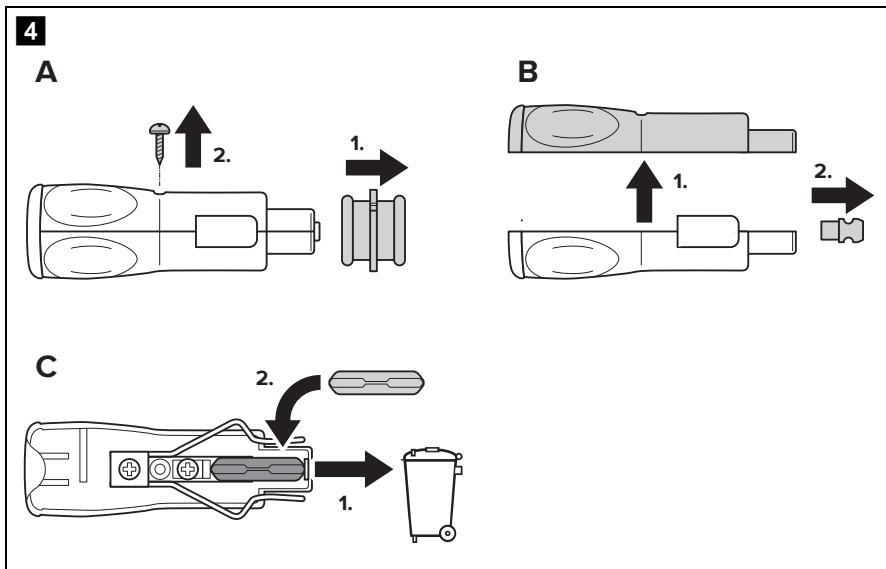

- Replace the fuse (8 A 32 V) as shown.

7 Cleaning and maintenance



WARNING!

Always disconnect the device from the power supply before you clean and service it.



NOTICE! Risk of damage

- Never clean the cooler under running water or in dish water.
- Do not use abrasive cleaning agents or hard objects during cleaning as these can damage the cooler.

- Occasionally clean the device interior and exterior with a damp cloth.

- Make sure that the air inlet and outlet vents on the device are free of any dust and dirt, so that heat can be released and the device is not damaged.

8 Warranty

The statutory warranty period applies. If the product is defective, please contact the manufacturer's branch in your country (see the back of the instruction manual for the addresses) or your retailer.

For repair and warranty processing, please include the following documents when you send in the device:

- A copy of the receipt with purchasing date
- A reason for the claim or description of the fault

9 Troubleshooting

Fault	Possible cause	Suggested remedy
The cooling device does not function, "POWER" LED does not glow.	No voltage present in the DC power socket in your vehicle.	The ignition must be switched on in most vehicles to supply current to the DC power socket.
	No voltage present in the AC voltage socket.	Try using another plug socket.
	The device AC fuse is defective.	Replace the device AC fuse (chapter "Replacing the AC fuse" on page 15).
	The integrated mains adapter is defective.	This can only be repaired by an authorised repair centre.
The cooling device does not cool (plug is inserted, "POWER" LED is lit).	Defective compressor.	This can only be repaired by an authorised repair centre.
The cooling device does not cool (plug is inserted, "POWER" LED flashes orange, display is switched off).	Battery voltage is too low.	Test the battery and charge it as needed.

Fault	Possible cause	Suggested remedy
When operating from the DC power socket: The ignition is on and the cooling device is not working.	The fitting of the DC power socket is dirty. This results in a poor electrical contact.	If the plug becomes very warm in the DC power socket fitting, either the fitting must be cleaned or the plug has not been assembled correctly.
	The fuse of the DC plug has blown.	Replace the fuse (8 A) of the DC plug with one of the same rating (chapter "Replacing the DC fuse" on page 16).
	The DC fuse inside the cooling device has blown.	This can only be repaired by an authorised repair centre.
The vehicle fuse has blown.	The vehicle fuse has blown.	Replace the vehicle's DC power socket fuse. Please refer to the operating manual of your vehicle.
The display shows an error message (e.g. "Err1") and the cooling device does not cool.	The appliance has switched off due to an internal fault.	This can only be repaired by an authorised repair centre.

10 Disposal

- Place the packaging material in the appropriate recycling waste bins wherever possible.



If you wish to finally dispose of the product, ask your local recycling centre or specialist dealer for details about how to do this in accordance with the applicable disposal regulations.

11 Technical data

	MCF40	MCF60
Item no.:	MCF40CB MCF40MB MCF40xx	MCF60CB MCF60MB MCF60xx
Connection voltage:	12/24 V \equiv 100 – 240 V \sim , 50/60 Hz	
Power consumption:	4 A (12 V \equiv) 2 A (24 V \equiv)	6 A (12 V \equiv) 3 A (24 V \equiv)
Cooling capacity:	1.0 – 0.4 A (100 – 240 V \sim) +10 °C to –16 °C (+50 °F to +3 °F)	
Gross capacity:	40 l	60 l
Usable capacity:	38 l	58 l
Climate class:	T	
Ambient temperature:	+16 °C to +43 °C	
Noise emission:	49 dB(A)	
Dimensions (W x H x D):	584 x 446 x 365 mm	680 x 470 x 440 mm
Weight:	11.5 kg	18.4 kg



NOTE

If the ambient temperature is above +32 °C (+90 °F), the minimum temperature cannot be attained.

Test/certificates:



The coolant circuit contains R134a.

For service/technical enquiries: 📞 **1800 212121**