

ASSEMBLY INSTRUCTIONS

MODEL : 097-000006

IMPORTANT NOTE :

- * PLACE ALL WOODEN PARTS ON A CLEAN AND SMOOTH SURFACE SUCH AS A RUG OR CARPET TO AVOID THE PARTS FROM BEING SCRATCHED.
- * BEFORE YOU BEGIN, KINDLY FOLLOW THE ASSEMBLY INSTRUCTIONS STEP BY STEP.

| HARDWARE LIST | | |
|---------------|--|------|
| A | JCBB M8 x 80mm + S/W 5/16" + F/W 5/16" x 22mm | 8PCS |
| B | ALLEN KEY M5 | 1PC |

| PART LIST | | |
|-----------|-----------|------|
| 1 | TABLE TOP | 1PC |
| 2 | TABLE LEG | 4PCS |

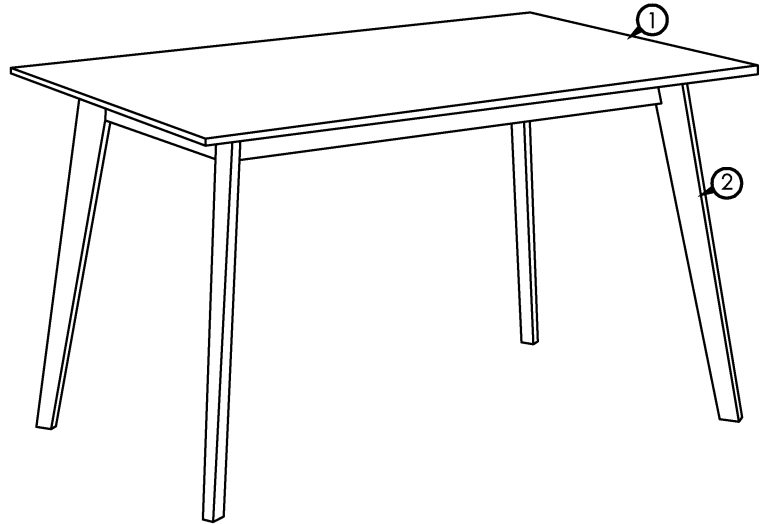

COMPLETED TABLE ASSEMBLY.

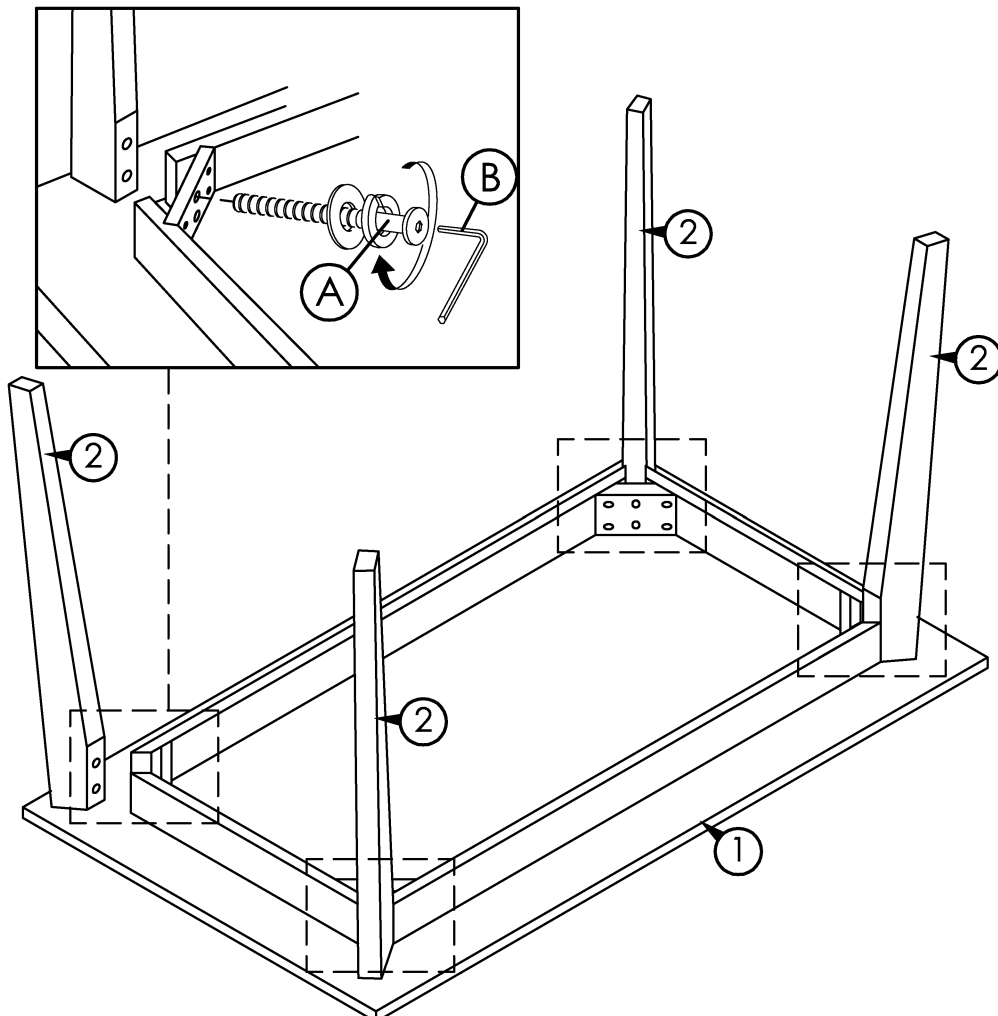

ASSEMBLY INSTRUCTIONS

MODEL : 097-000008



IMPORTANT NOTE :

- * PLACE ALL WOODEN PARTS ON A CLEAN AND SMOOTH SURFACE SUCH AS A RUG OR CARPET TO AVOID THE PARTS FROM BEING SCRATCHED.
- * BEFORE YOU BEGIN, KINDLY FOLLOW THE ASSEMBLY INSTRUCTIONS STEP BY STEP.
- * DO NOT TIGHTEN ALL SCREWS UNTIL THE CHAIR IS FULLY SET-UP.

| HARDWARE LIST | | PART LIST | |
|---------------|---|-----------|------------------------|
| A | JCBC M6 x 25mm + S/W M6 + F/W M6 x 13mm  | 4PCS | 1 RIGHT SIDE FRAME 1PC |
| B | JCBC M6 x 45mm + S/W M6 + F/W M6 x 13mm  | 4PCS | 2 LEFT SIDE FRAME 1PC |
| C | ALLEN KEY M4  | 1PC | 3 FRONT STRETCHER 1PC |
| D | L BRACKET  | 4PCS | 4 BACK STRETCHER 1PC |
| E | PH SCREW M4 x 12mm  | 8PCS | 5 TOP REST 1PC |
| F | WOOD DOWEL M8 x 25mm  | 2PCS | 6 CUSHION SEAT 1PC |

CAUTIONS :

(1) DO NOT FULLY-TIGHTEN THE NUT OR NUT BOLTS INITIALLY UNTIL ALL NUTS OR BOLT IS READY ASSEMBLED.

(TO AVOID CAUSING DAMAGES TO THE THREAD, DO NOT OVER-TIGHTEN THE NUTS OR BOLTS.)

(2) KEEP ALL HARDWARE PART OUT OF REACH OF CHILDREN.

STEP 1

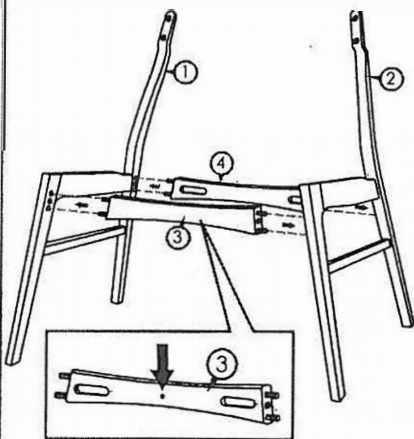

Front Stretcher has a small hole for identification.

STEP 2

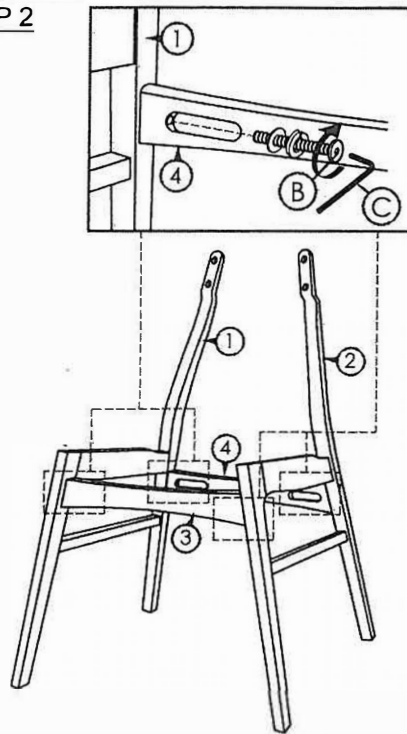

STEP 3

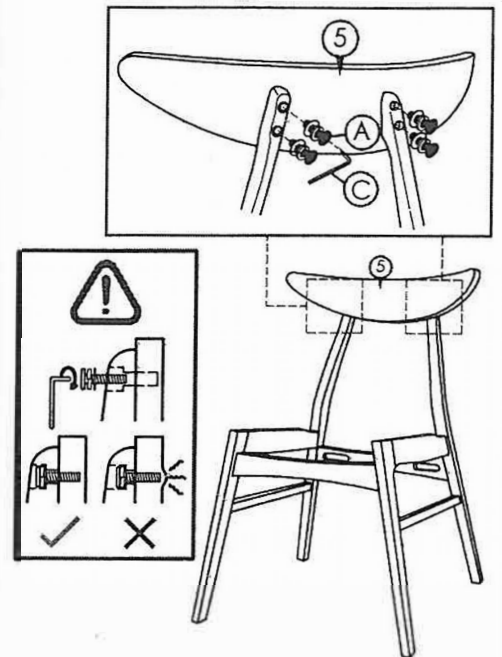

STEP 4

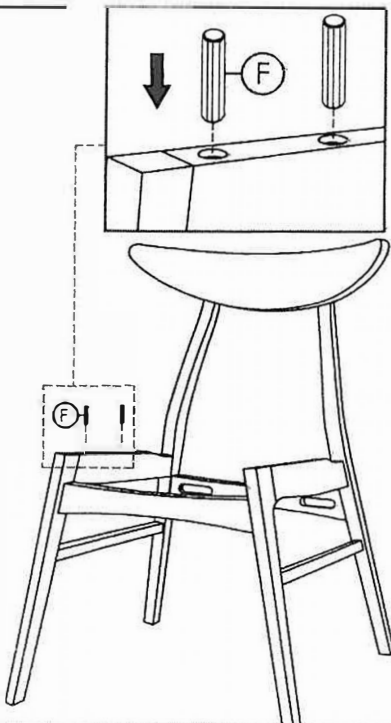

STEP 5

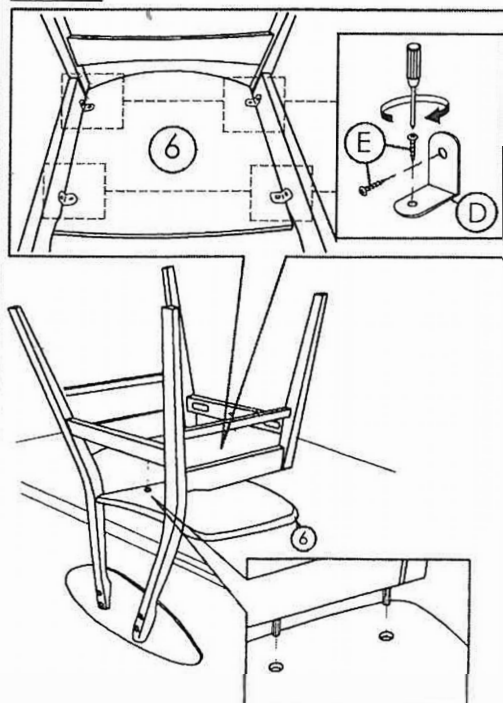

STEP 6



COMPLETED CHAIR ASSEMBLY.