

TRITON

T60X

electric shower

**REGISTER ONLINE
ENTER A PRIZE DRAW**

**WIN
£100**

RETAIL VOUCHERS

VISIT OUR WEBSITE TODAY

TRITONSHOWERS.CO.UK/REGISTER

THIS OFFER IS NOT VALID OUTSIDE THE UK



FOR YOUR SERVICE REFERENCE

NOTE DOWN THE PRODUCT CODE BELOW
(FROM THE FRONT OR TOP OF THE BOX)

ALTERNATIVELY REGISTER BY TEL: 024 7637 8321

IMPORTANT SAFETY ADVICE

The shower unit **MUST BE** switched off at the isolating switch when not in use. This is a safety procedure recommended for all electrical appliances.

The shower head and hose supplied with this product are a safety critical part of your shower. Failure to use genuine Triton parts may cause injury and invalidate your guarantee.

INSTALLATION AND OPERATING INSTRUCTIONS

Please read this book thoroughly and familiarise yourself with all instructions before commencing installation and keep it for future reference.

The shower installation **MUST** be carried out by a suitably qualified person, **in the sequence of this instruction book.**



PLEASE READ THIS IMPORTANT SAFETY INFORMATION

Products manufactured by Triton are safe and without risk provided they are installed, used and maintained in good working order in accordance with our instructions and recommendations.

- ⚠ WARNING: DO NOT** operate the appliance if frozen, or suspected of being frozen. It must thaw out before using.
- ⚠ DO NOT** operate the appliance if the shower head or spray hose becomes damaged.
- ⚠ DO NOT** restrict flow out of the appliance by placing shower head in direct contact with your body.
- ⚠ DO NOT** operate the appliance if water ceases to flow during use or if water has entered the unit because of an incorrectly fitted cover.
- ⚠ WARNING: If restarting the appliance immediately after stopping, be aware that a slug of hot water will be expelled for the first few seconds.**
- ⚠** The shower head must be descaled regularly.
- ⚠** Fit only shower heads recommended by the manufacturer and never fit any additional device to restrict the water outlet flow.
- ⚠** The outlet must not be connected to any tap or fitting other than those specified.
- ⚠** This appliance is intended to be permanently connected to the water mains and not connected by a hose set.
- ⚠** A suitable double pole isolation switch for supply disconnections must be incorporated in the fixed wiring circuit in accordance with current wiring rules. See Electrical Installation section for further details.
- ⚠** The water inlet of this appliance shall not be connected to inlet water obtained from any other water heating system.

Mains water pressure only.
Minimum inlet pressure 100kPa (1 bar) 150kPa (1.5 bar) for 10.5kW
Maximum inlet pressure 1000kPa (10 bar)

This book contains all the necessary fitting and operating instructions for your electric shower.

Care taken during the installation will provide a long, trouble-free life from your shower.

⚠ WARNING ⚠

This appliance can be used by children aged from 3 years and above and persons with reduced physical, sensory or mental capabilities or lack of experience and knowledge if they have been given supervision or instruction concerning use of the appliance in a safe way and understand the hazards involved. Children may not play with the appliance. Cleaning and user maintenance shall not be made by children.



**IMPORTANT - PLEASE READ THESE
GENERAL GUIDANCE NOTES BEFORE PROCEEDING**



1 GENERAL

- 1.1 Isolate the electrical and water supplies before removing the cover.
- 1.2 Read all of these instructions and retain them for later use.
- 1.3 **DO NOT** take risks with plumbing or electrical equipment.
- 1.4 Isolate electrical and water supplies before proceeding with the installation.
- 1.5 The unit must be mounted onto the finished wall surface (on top of the tiles). **DO NOT** tile up to or seal around **ANY PART** of the unit using silicone sealer after fixing to the wall. Special care must be taken **NOT TO BLOCK OR SEAL ANY PRD VENTS ON THE UNIT**.
- 1.6 Contact Customer Experience (*see back page*), if any of the following occur:
 - a) *If it is intended to operate the shower at pressures above the maximum or below the minimum stated.*
 - b) *If the unit shows a distinct change in performance.*
 - c) *If the shower is frozen.*
- 1.7 If it is intended to operate the shower in areas of hard water (above 200 ppm temporary hardness), a scale inhibitor may have to be fitted. For advice on the Scale Inhibitor, contact Customer Experience.
- 1.8 The shower head must be cleaned regularly with descalent to remove scale and debris, otherwise restrictions to the flow on the outlet of the unit will result in higher temperatures and could also cause the (PRD) Pressure Relief Device in the unit to operate.
- 1.9 This product is not suitable for mounting into steam rooms or steam cubicles.

2 PLUMBING

- 2.1 The plumbing installation must comply with Water Regulations, Building Regulations or any particular regulations as specified by Local Water Company or Water Undertakers and should be in accordance with BS EN 806.
- 2.2 The supply pipe must be flushed to clear debris before connecting to the shower unit.

- 2.3 **DO NOT** solder pipes or fittings within 300mm of the shower unit, as heat can transfer along the pipework and damage components.
- 2.4 **DO NOT** fit any form of outlet flow control as the outlet acts as a vent for the heater can.
- 2.5 **DO NOT** use excessive force when making connections to the flexible hose or shower head, finger tight is sufficient.
- 2.6 All plumbing connections must be completed before making the electrical connections.
- 2.7 This appliance **MUST NOT** be connected to the inlet supply by a hose-set.

3 ELECTRICAL

- 3.1 The installation must comply with BS 7671 'Requirements for electrical installations' (IEE wiring regulations), building regulations or any particular regulations as specified by the local Electrical Supply Company.
- 3.2 This appliance **MUST** be earthed.
- 3.3 In accordance with 'The Plugs and Sockets etc. (Safety) Regulations 1994', this appliance is intended to be permanently connected to the fixed wiring of the electrical mains system.
- 3.4 Make sure all electrical connections are tight to prevent overheating.
- 3.5 A 30mA residual current device (RCD) **MUST** be installed in all UK electric and pumped shower circuits. This may be part of the consumer unit or a separate unit.
- 3.6 Switch off immediately at isolating switch if water ceases to flow during use.
- 3.7 Other electrical equipment i.e. extractor fans, pumps must not be connected to the circuits within the unit.
- 3.8 Switch off at isolating switch when not in use. This is a safety procedure recommended with all electrical appliances.
- 3.9 As with all electrical appliances it is recommended to have the shower and installation checked at least every two years by a competent electrician to ensure there is no deterioration due to age and usage.

This book contains all the necessary fitting and operating instructions for your electric shower. Please read them carefully.

The shower installation must be carried out by a suitably qualified person and in the sequence of this instruction book.

Care taken during the installation will guarantee a long, trouble-free life from your shower.

SPECIFICATIONS

Electrical

| | |
|------------------------------|------------------------------|
| Nominal power rating at 240V | Nominal power rating at 230V |
| 8.5kW – (40A MCB rating) | 7.9kW – (40A MCB rating) |
| 9.5kW – (40A MCB rating) | 8.7kW – (40A MCB rating) |
| 10.5kW – (45A MCB rating) | 9.6kW – (40A MCB rating) |

Water

Inlet connection – 15mm diameter.

Outlet connection – ½" BSP male thread.

Entry Points

Water – **Right:** top, back bottom, bottom.

Cable – **Right:** top, middle back, bottom.

Materials

Backplate, cover, controls, shower head – ABS.

Sprayplate – Acetal.

Elements – Mineraally insulated corrosion resistant metal sheathing.

Dimensions

Height – 230mm

Width – 217mm

Depth – 103mm

Standards and Approvals

Splashproof rating IPX4.

Complies with the requirements of current British and European safety standards for household and similar electrical appliances.

Complies with requirements of the British Electrotechnical Approvals Board (BEAB).

Meets with Compliance with European Community Directives (CE) and UK Community Directives (UKCA).

ADVICE TO USERS

The following points will help you understand how the shower operates:

- a. The electric heating elements operate at a constant rate at your chosen power setting. It is the rate of the water passing through the heater can which determines the water temperature. The slower the flow the hotter the water becomes, and the faster the flow the cooler the water.
- b. During winter, the mains water supply will be cooler than in summer, so the temperature of the shower will vary between seasons on any one setting of the temperature control. At different times of the year you may have to adjust the position of the temperature control to maintain your desired temperature setting.
- c. The stabiliser valve minimises variations in shower temperature during mains water pressure changes. If changes in shower temperature are experienced during normal use, it will most likely be caused by the water pressure falling near to or below the minimum level. The drop in pressure may be due to water being drawn off at other points in the house while the shower is in use. If pressure drops appreciably below the minimum, the heating elements will automatically cut out.

If ever the water becomes too hot and you cannot obtain cooler water, first check that the sprayplate in the shower head has not become blocked.

DO NOT place items such as soap or shampoo bottles on top of the unit. Liquid could seep through the joint between the cover and backplate, and possibly damage the sealing rubber.

| CONTENTS | Page |
|---|-------------|
| Important Safety Information and Guidance Notes | 2 - 3 |
| Specifications..... | 4 |
| Advice to users | 4 |
| Key to main components..... | 6 |
| Electrical requirements..... | 7 – 8 |
| Water requirements | 9 |
| Siting of the shower..... | 10 |
| Fixing the shower to the wall..... | 11 - 12 |
| Plumbing connections | 13 |
| Electrical connections | 14 |
| Replacing the cover | 15 |
| Commissioning..... | 16 |
| Operating the shower | 17 |
| Operating functions..... | 18 |
| Spare parts | 19 |
| Fault finding | 20 – 20 |
| Water/Cable entry points diagram | 22 |
| Guarantee, service policy, etc..... | rear cover |

To check the product suitability for commercial and multiple installations, please contact Triton's specification advisory service before installation.

Telephone: 024 7637 2222

Email: technical@tritonshowers.co.uk

MAIN COMPONENTS

1. Top pipe/cable entry
2. Bottom pipe/cable entry
3. Area for rear pipe and cable entry
4. Water inlet
5. Wall screw fixings
6. Cover screw fixings
7. Terminal block
8. Power selector assembly
9. Stabilising valve
10. Can and element assembly
11. Thermal cut-out
12. Pressure relief device – PRD
13. Shower outlet

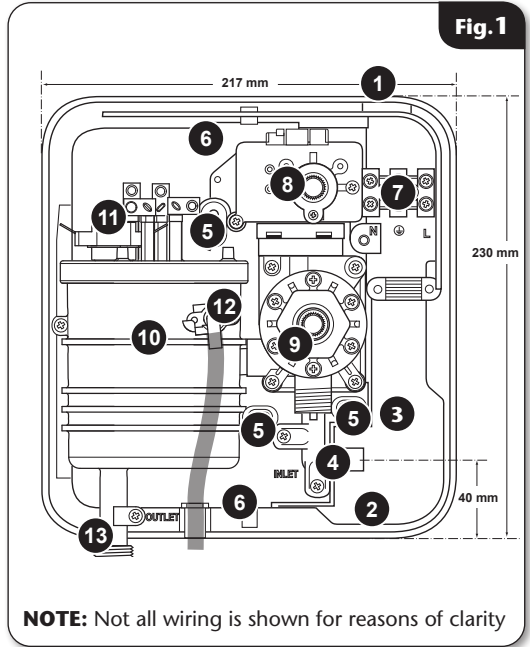

ELECTRICAL REQUIREMENTS

⚠ WARNING! ⚠
THIS APPLIANCE MUST BE EARTHED

The installation, supply cable and circuit protection must conform with BS 7671 (IEE wiring regulations) and be sufficient for the amperage required.

The following notes are for guidance only:

- 1 The shower must only be connected to a 230-240V ac supply. If you are installing a shower with a kilowatt rating above 9kW, it is advisable to contact the local electricity supply company.
- 1.1 The electrical rating of the shower is shown on the rating label (Fig.2) within the unit.
- 2 Before making any sort of electrical connection within the installation, make sure that no terminal is live. If in any doubt, switch off the whole installation at the mains supply and remove the correct fuse.
- 3 The shower must be connected to its own independent electrical circuit. **IT MUST NOT** be connected to a ring main, spur, socket outlet, lighting circuit or cooker circuit.
- 3.1 The electrical supply must be adequate for the loading of the unit and existing circuits.
- 4 Check your consumer unit (main fuse box) has a main switch rating of 80A or above and that it has a spare fuse way which will take the fuse or Miniature Circuit Breaker (MCB) necessary for the shower (Fig.3).
- 4.1 If your consumer unit has a rating below 80A or if there is no spare fuse way, then the installation will not be straightforward and may require a new consumer unit serving the house or just the shower.
- 4.2 You will need to contact the local electricity company. They will check the supply and carry out what is necessary.
- 5 For close circuit protection **DO NOT** use a rewirable fuse. Instead use a suitably rated Miniature Circuit Breaker (MCB) or cartridge fuse (see Table A).
- 5.1 A 30mA residual current device (RCD) **MUST** be installed in all UK electric and pumped shower circuits. This may be part of the consumer unit or a separate unit.

Fig.2 Illustrative purposes only



Fig.3 Schematic of installation circuit

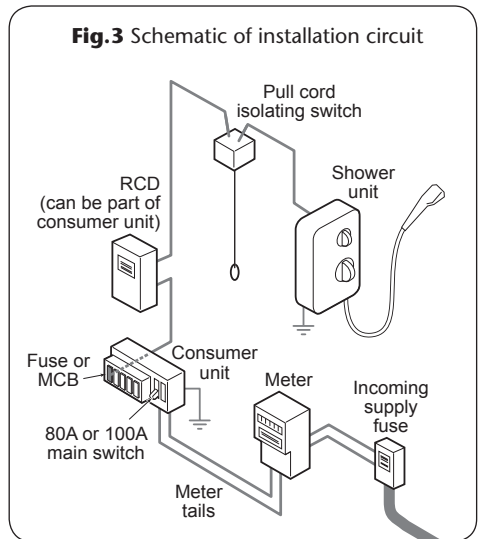

Table A

| CIRCUIT PROTECTION | | |
|--------------------|--------|----------------|
| unit rating | MCB | cartridge fuse |
| 7.0kW | 30/32A | 30A |
| 7.5kW | 32A | 35A |
| 8.0kW | 40A | 35A |
| 8.5kW | 40A | 45A |
| 9.0kW | 40A | 45A |
| 9.5kW | 40/45A | 45A |
| 10.5kW | 45A | 45A |

- 6 A 45 amp double pole isolating switch with a minimum contact gap of 3mm in both poles must be incorporated in the circuit.
- 6.1 It must have a mechanical indicator showing when the switch is in the OFF position, and the wiring must be connected to the switch without the use of a plug or socket outlet.
- 6.2 The switch must be accessible and clearly identifiable, but out of reach of a person using a fixed bath or shower, except for the cord of a cord operated switch, and should be placed so that it is not possible to touch the switch body while standing in a bath or shower cubicle. It should be readily accessible to switch off after using the shower.
- 7 Where shower cubicles are located in any rooms other than bathrooms, all socket outlets in those rooms must be protected by a 30mA RCD.
- 8 The current carrying capacity of the cable must be at least that of the shower circuit protection (see Table B).
- 8.1 To obtain full advantage of the power provided by the shower, use the shortest cable route possible from the consumer unit to the shower.
- 8.2 It is also necessary to satisfy the disconnection time and thermal constraints which means that for any given combination of current demand, voltage drop and cable size, there is a maximum permissible circuit length.
- 9 The shower circuit should be separated from other circuits by at least twice the diameter of the cable or conduit.
- 9.1 The current rating will be reduced if the cabling is bunched with others, surrounded by thermal loft or wall insulation or placed in areas where the ambient temperature is above 30°C. Under these conditions, derating factors apply and it is necessary to select a larger cable size.
- 9.2 In the majority of installations (see Table B), the cable will unavoidably be placed in one or more of the above conditions. This being so, it is strongly recommended to use a minimum of 10mm cabling throughout the shower installation.

- 9.3 In any event, it is essential that individual site conditions are assessed by a competent electrician in order to determine the correct cable size and permissible circuit length.

Table B

| Twin and earth PVC insulated cable Current carrying capacity | | |
|---|----------------------------|---|
| Installed in an insulated wall | In conduit trunking | Clipped direct or buried in a non-insulated wall |
| 6mm ² 32A | 6mm ² 38A | 6mm ² 46A |
| 10mm ² 43A | 10mm ² 52A | 10mm ² 63A |
| 16mm ² 57A | 16mm ² 69A | 16mm ² 85A |

Note: Cable selection is dependent on derating factors

***The method below may be used by installers to determine the approximate size of the incoming cable.**

6mm²



10mm²



16mm²



1. Measure the width of an individual strand, and half that measurement to find (r), e.g: $1.34mm \div 2 = (r) 0.67mm$
2. Multiply (r) x (r) x 3.14, e.g: $(r) 0.67 \times (r) 0.67 \times 3.14 = 1.41mm^2$
3. Multiply this by the number of wire strands (usually 7), e.g: $1.41mm^2 \times 7 = 9.87mm^2$.
4. The number obtained would suggest 10mm² wiring.

***PLEASE NOTE: If unsure, consult a qualified Electrician.**

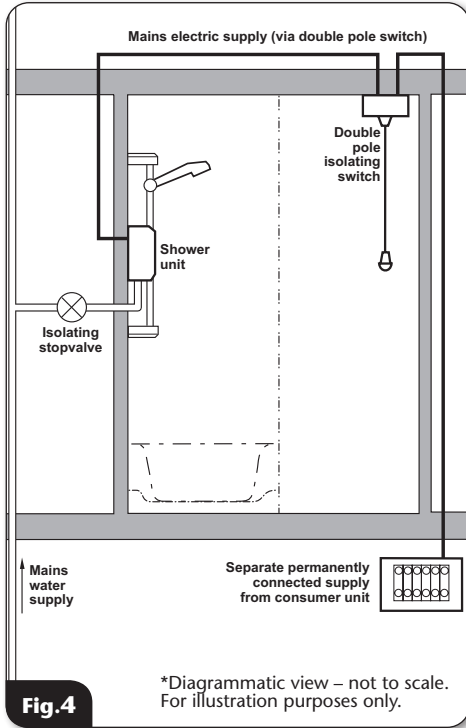

WATER REQUIREMENTS

The installation must be in accordance with Water Regulations/Bylaws.

To guarantee activating the heating elements, the shower must be connected to a mains water supply with a minimum running pressure of 100kPa (1.0 bar) at a minimum flow rate of eight litres per minute, and a maximum static pressure of 1 000kPa (10 bar) for 8.5 and 9.5Kw.

10.5Kw requires 150kPa (1.5 bar) at a minimum flow rate of eleven litres per minute, and a maximum static pressure of 1 000kPa (10 bar).

NOTE: If the stated flow rates are not available, it may not be possible to achieve optimum performance from the unit throughout the year.

During periods of high ambient temperatures it may be necessary to select a low power setting to achieve your preferred shower temperature.

If it is intended to operate the shower at pressures above the maximum or below the minimum stated, contact Customer Experience for advice.

Fig.4 shows a typical system layout.

DO NOT use jointing compounds on any pipe fittings for the installation.

SITING OF THE SHOWER

IMPORTANT: If installing onto a tiled wall always mount the unit on the surface of the tiles. NEVER tile up to the unit.

Refer to **fig.5** for correct siting of shower. Position the unit where it will NOT be in direct contact with water from the shower head. Position the shower unit vertically.

Allow enough room between the ceiling and the shower to access the cover top screws.

NOTE: Water Regulations requires the shower head be 'constrained by a fixed or sliding attachment so that it can only discharge water at a point not less than 25mm above the spill-over level of the relevant bath, shower tray or other fixed appliance'. The use of the supplied soap dish will in most cases meet this requirement, but if the shower head can be placed within a bath, basin or shower tray, then a double check valve, or similar, must be fitted in the supply pipework to prevent back-flow.

Pressure Relief Safety Device

A pressure relief device (PRD) is designed into the shower unit which complies with European standards. The PRD provides a level of appliance protection should an excessive build up of pressure occur within the shower.

DO NOT operate the shower with a damaged or kinked shower hose, or a blocked shower head which can cause the PRD to operate.

When commissioning, the shower head must be removed from the flexible hose, while at the same time the temperature control must be at the minimum flow position. Failure to follow this procedure may also cause the PRD to operate.

Make sure the shower is positioned over a bath or shower tray because if the PRD operates, then water will eject from the bottom of the unit.

Should this happen, turn off the electricity and water supplies to the shower at the isolating switch and stopvalve. Contact Customer Experience for advice on replacing the PRD.

WARNING!
THE SHOWER MUST NOT BE POSITIONED WHERE IT WILL BE SUBJECTED TO FREEZING CONDITIONS.

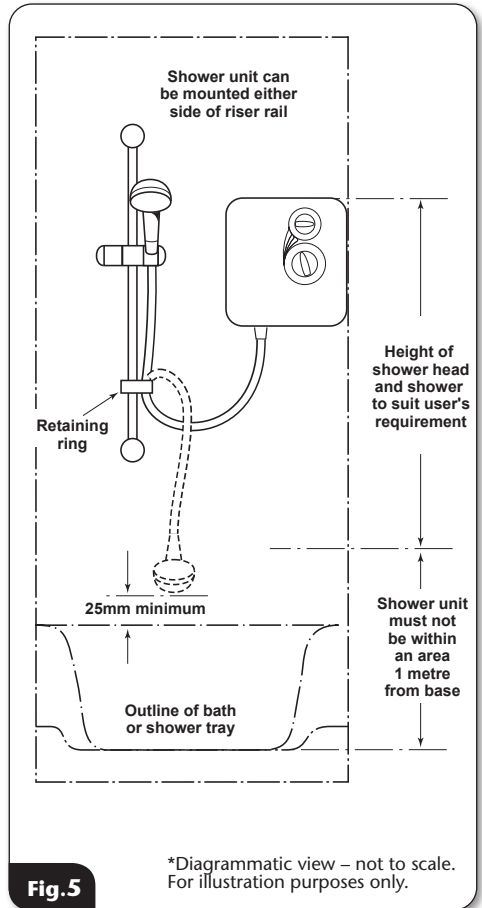
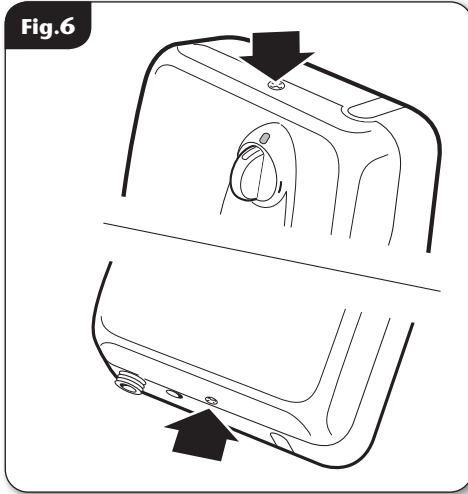

Fig.5

IMPORTANT: The unit must be mounted on a flat surface which covers the full width and length of the backplate. It is important that the wall surface is flat otherwise difficulty may be encountered when fitting the cover and subsequent operation of the unit may be impaired.

Fig.6



FITTING THE SHOWER TO THE WALL

WARNING!

Check there are no hidden cables or pipes before drilling holes for wall plugs. Use great care when using power tools near water. The use of a residual current device (RCD) is recommended.

Unscrew the top and bottom retaining screws (**fig.6**) and lift the cover from the backplate.

NOTE: The control knobs are an integral part of the cover — do not attempt to remove them.

Entry positions for the mains water and electrical supplies are at the top, bottom, or at the rear of the unit.

If a bottom entry has been chosen, fit the appropriate cut-out in the top of the backplate (**fig.7**).

If a top entry has been chosen, fit the appropriate cut-out in the bottom of the backplate (**fig.8**).

Fig.7

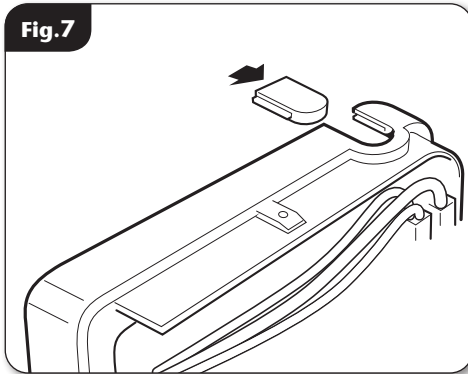
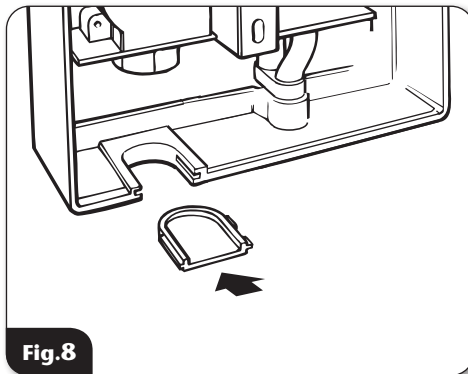

Fig.8



NOTE: Deviations from the designated entry points will invalidate product approvals.

If installing a feed pipe from the back or bottom, the centre of the inlet valve to the wall surface is 20mm (**fig.9**).

NOTE: If entry is from the back, the nut of the compression fitting will be partially behind the surface of the wall (**fig.9**). This area **MUST** be left clear when plastering over the pipework in order to make the nut accessible for future adjustments.

After choosing the site for the shower, use the backplate as a template and mark the top fixing hole and one of the lower holes (**fig.10**).

Drill and plug the wall. An appropriate drill bit should be used. If the wall is brick, plasterboard or a soft building block, appropriate wall plugs and screws should be fitted.

Screw top fixing screw into position leaving the base of the screw head protruding 6mm out from the wall.

Hook the backplate over the top screw and fit the bottom fixing screw into position.

NOTE: Do not fully tighten the screws at this stage, as the fixing holes are elongated to allow for out of square adjustment after the plumbing connections have been completed.

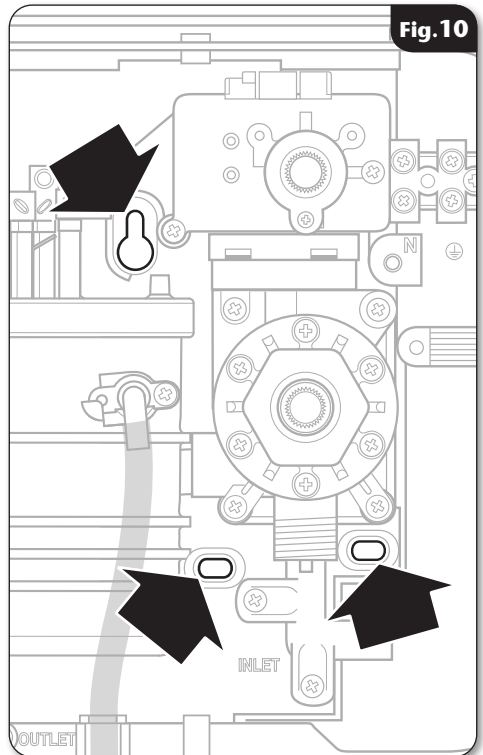
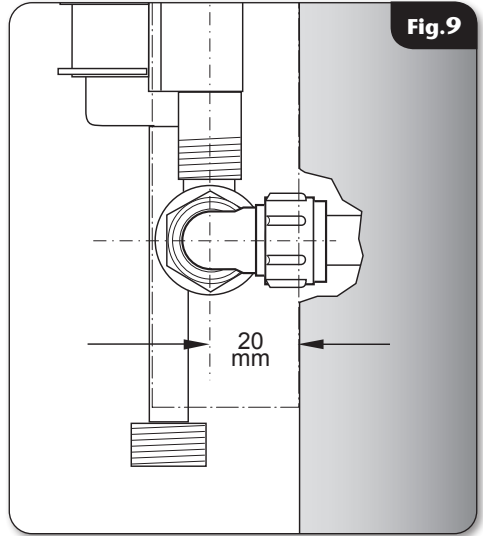
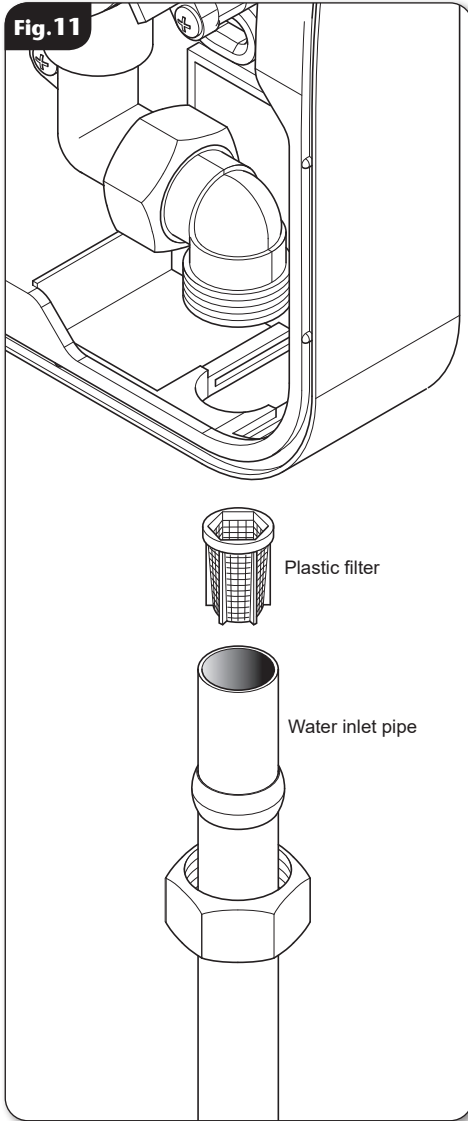

Fig. 11



Plastic filter

Water inlet pipe

PLUMBING CONNECTIONS

Plumbing to be carried out before wiring.

DO NOT use jointing compounds on any pipe fittings for the installation.

DO NOT solder fittings near the area of the shower unit as heat can transfer along the pipework and damage components.

Compression fittings **MUST** be used to connect to the inlet of the shower.

NOTE: An additional stopvalve (complying with Water Regulations) **MUST** be fitted in the mains water supply to the shower as an independent means of isolating the water in order to carry out maintenance or servicing. If this isolator is fitted in a loft space, the loft must have a fixed access ladder and be boarded, with appropriate lighting from the access point to the isolator.

Procedure

Turn off the water supply either at the mains stopvalve or the isolating stopvalve. Insert the plastic inlet filter into the 15mm piping (**fig. 11**) and connect the mains water supply to the inlet of the shower via 15mm copper, stainless steel or plastic pipe using a 15mm x 15mm brass compression fitting.

NOTE: The inlet fitting is designed to enter a compression fitting only. DO NOT use push fit connectors as full engagement cannot be guaranteed. DO NOT use excessive force when making these connections.

Make sure the backplate is square on the wall and tighten the two retaining screws which hold it to the wall.

Before turning on the mains water supply, the stabilising valve should be fully closed. To make sure that it is, replace the cover temporarily to engage the splines and rotate the temperature control fully clockwise until a 'stop' is felt. The valve is now in the closed position. Remove the cover.

Turn on the mains water supply and check for leaks in the pipework connection to the shower.

NOTE: At this stage no water can flow through the unit.

WARNING!

The outlet of the shower acts as a vent and must not be connected to anything other than the hose and shower head supplied.

ELECTRICAL CONNECTIONS

SWITCH OFF THE ELECTRICITY SUPPLY AT THE MAINS.

Fig.12 shows a schematic wiring diagram.

The cable entry points are shown in **Water/ Cable Entry Points diagram**.

The cable can be surface clipped, hidden or via 20mm conduit.

NOTE: Conduit entry can only be from rear. Route the cable into the shower unit and connect to the terminal block (**fig.13**) as follows:

Earth cable to terminal marked **E** 

Neutral cable to terminal marked **N**

Live cable to terminal marked **L**

Important: Fully tighten the terminal block screws and check that no cable insulation is trapped under the screws. Loose connections can result in cable overheating.

NOTE: The supply cable earth conductor must be sleeved. The outer sheath of the supply cable must be stripped back to the minimum.

The supply cable must be secured either by routing through conduit or in trunking or by embedding in the wall, in accordance with current IEE regulations.

The use of connections within the unit, or other points in the shower circuit, to supply power to other equipment i.e. extractor fans, pumps, etc. will invalidate the guarantee.

DO NOT switch on the electricity supply until the cover has been fitted.

Fig.12

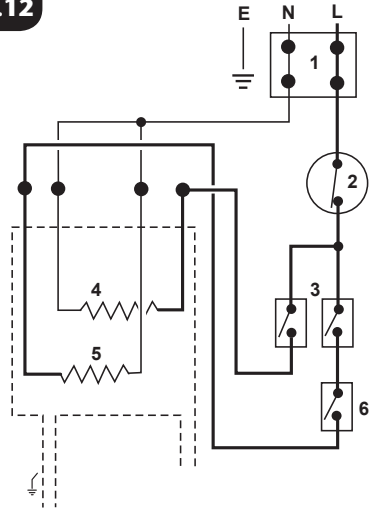

1. Terminal block
2. Thermal cut-out (main)
3. Microswitches
4. Element

5. Element
6. Microswitch

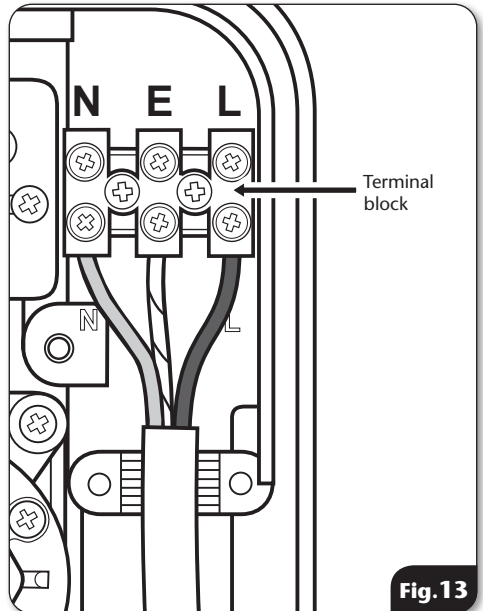
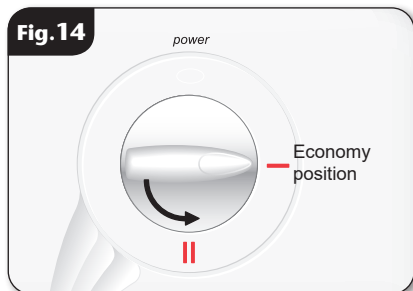

Fig.13

Fig. 14



REPLACING THE COVER

Position the power selector on the cover to the **ECONOMY** position (**fig.14**).

Make sure the power selector spindle is aligned with the screw at the 6 o'clock position as shown in **fig.15**.

To make sure that the temperature control is correctly positioned on the stabilising valve, temporarily place the cover in position so that the splines engage and rotate the temperature control fully clockwise until a 'stop' is felt (**fig.15**).

Fig. 15

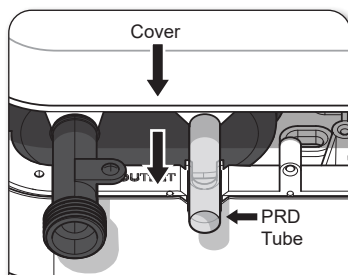
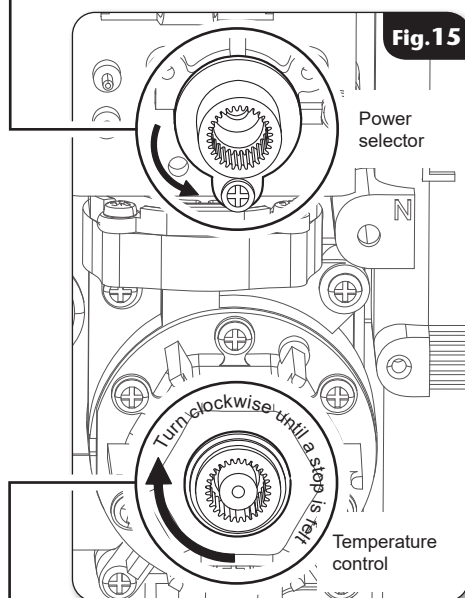

WARNING!
The PRD tube **MUST** be positioned correctly when fitting the cover. Failure to do so may damage the unit if the PRD operates and will invalidate product warranty and approvals.

Fig. 16

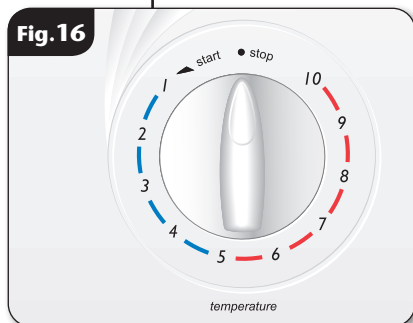

The valve is now in the closed position.

Remove the cover and position the temperature control so that it points towards the **STOP** position (**fig.16**).

Replace the cover squarely to the backplate and guide into position so that the knobs locate correctly into the spindle. Should any difficulty arise, recheck the points above.

Secure the cover in position with the two retaining screws.

DO NOT switch on the electricity supply to the shower until the commissioning has been carried out.

COMMISSIONING

WARNING!

Before normal operation of the shower, it is essential the following commissioning procedure is completed correctly.

The first operation of the shower is intended to flush out any unit debris and to guarantee that the heater unit contains water before the elements are switched on. This operation must be carried out with the electricity switched OFF at the isolating switch and **WITHOUT** the shower head attached to the flexible hose. Make sure the outlet of the hose is directed to waste.

Check the water supply is turned OFF at the isolating stopvalve.

Rotate the temperature control fully anti-clockwise to number 10, the minimum flow position (**fig.17**).

NOTE: Leaving the control at any position other than 10 may cause the PRD to operate.

Turn the water supply back ON at the isolating stopvalve.

Wait until water starts to flow from the flexible hose, then slowly rotate the temperature control clockwise to number 1, the maximum flow position (**fig.18**).

It will take approximately thirty seconds for a smooth flow of water to be obtained whilst air and any debris is being dispersed from the shower. When a smooth flow of water is obtained, rotate the temperature control from 1 to 10 and back again several times to release any trapped air within the unit.

Once the flushing out has been completed, stop the water flow by rotating the temperature control fully clockwise to the STOP position.

Fit the shower head to the flexible hose and place in the holder.

Switch on the electricity supply to the shower at the isolating switch.

The shower is now ready for normal operation.

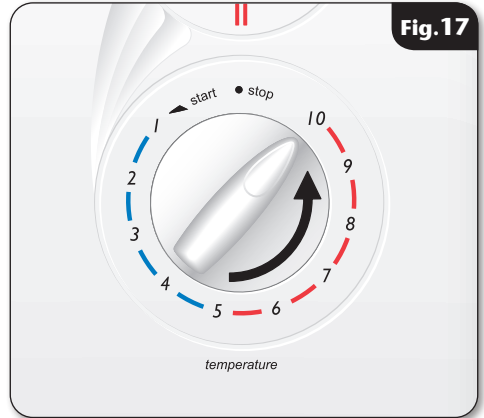

Fig.17

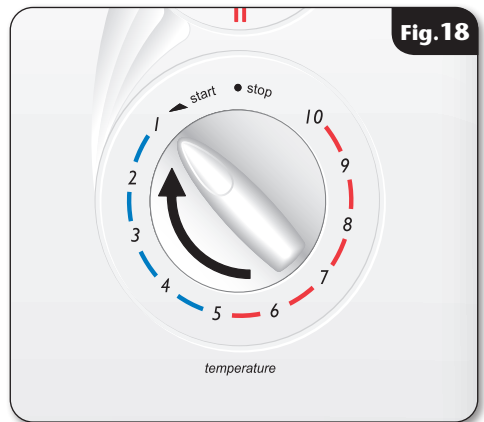

Fig.18



WARNING

COVER RETAINING SCREWS

ONLY the **SUPPLIED SCREWS** should be used. The use of non supplied screws **WILL** invalidate product specifications & warranty.

Fig.19

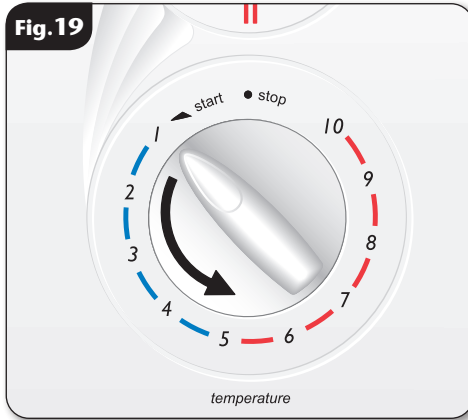

OPERATING THE SHOWER

The flow of water is controlled by the START/STOP temperature control. To obtain warm water turn the control slowly anti-clockwise to the mid position, i.e. numbers 5 or 6 (**fig.19**).

If the water is too hot, turn the temperature control slowly clockwise towards the lower numbers (**fig.20**).

If the water is too cool, turn the temperature control slowly anti-clockwise towards the higher numbers (**fig.21**).

To stop the shower turn the temperature control fully clockwise to the STOP position and water will cease to flow.

Fig.20

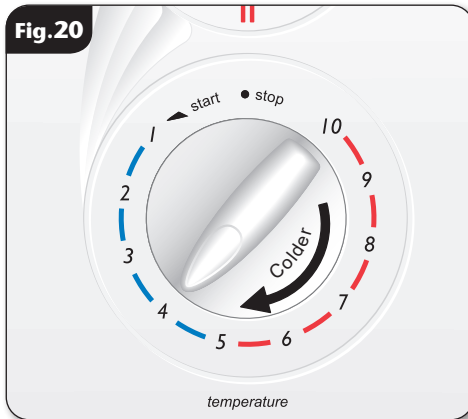
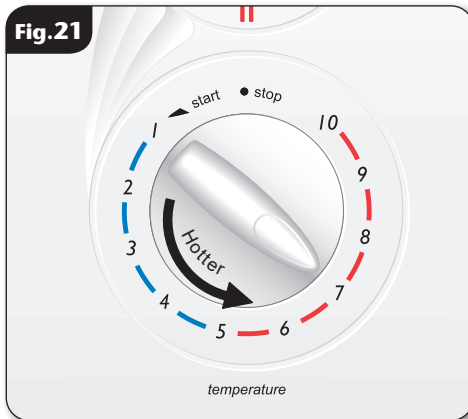

Fig.21



Power Selector

The power selector has two positions, ECONOMY and HIGH (**fig.22**).

The **single red symbol** is the economy setting for using less power during warmer months when the ambient water temperature is high.

NOTE: If the stated flow rate required for the unit cannot be met due to low water pressure, it will be necessary to operate the unit on this setting during the warmer months because of flow rate limitations entering the unit.

The **double red symbol** is the high setting which allows the highest flow achievable for your preferred temperature. This setting should be regarded as normal for optimum shower performance throughout the year.

NOTE: It is advisable to be certain that the showering temperature is satisfactory by testing with your hand before stepping under the shower head.

There will always be a time delay of a few seconds between selecting a flow rate and the water reaching the stable temperature for that flow rate.

OPERATING FUNCTIONS

Low Water Pressure Cut-out

If the water pressure falls below the minimum required for correct operation of the shower, power will be switched off to the heating elements preventing any maintained temperature rises - water will continue to flow. Power will automatically be restored when adequate water pressure returns.

Temperature Limiter

During normal operation, if an overheat temperature is sensed, power to the elements will be reduced - water will continue to flow. When the temperature has cooled sufficiently, power to the elements will be automatically restored to the previous setting at the time of interruption.

Safety Cut-out

The unit is fitted with a thermal cut-out safety device. In the event of abnormal operation which could cause unsafe temperatures within the unit, the device will disconnect the power supply to the heating elements. It will require a visit from a qualified engineer to determine the nature of the fault and replace the safety cut-out device once the unit has been repaired.

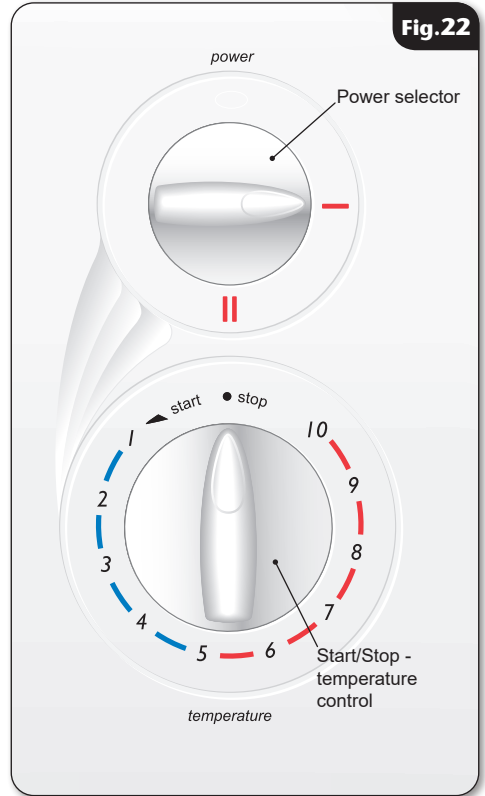

NOTE: In normal use, it is in order to leave the water supply permanently on to the shower unit, but as with most electrical appliances, **the unit must be switched off at the isolating switch when not in use.**

WARNING!
After any servicing of the mains water supply, always start the unit with the electricity OFF at the isolating switch and then rotate the temperature control fully anti-clockwise in order to purge any air in the pipework.

SPARE PARTS

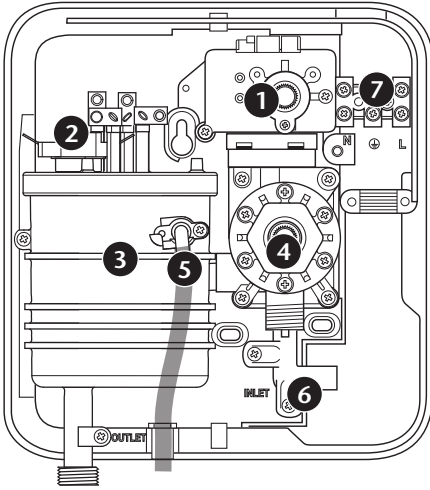

| Ref. | Description | Part No. |
|------|---|-----------|
| 1. | Selector switch assembly..... | S25711020 |
| 2. | Thermal cut-out (can)..... | 22012250 |
| 3. | Heater can assembly (8.5kW) | P25910700 |
| | (9.5kW) | P25910701 |
| | (10.5kW) | P25910702 |
| 4. | Stabiliser valve assembly (incl. inlet elbow) (8.5Kw & 9.5Kw)..... | 82600720 |
| | (10.5Kw) | S25710800 |
| 5. | Pressure Relief Device..... | 82800450 |
| 6. | Inlet elbow..... | 7051625 |
| | – Microswitch & wire assy..... | P07820905 |
| | (single) | |
| | – Microswitch & wire assy..... | P07820906 |
| | (double) | |
| | – Earth wire (can) | 2160560 |
| 7. | Terminal block & wires (8.5Kw & 9.5Kw)..... | S25711010 |
| | (10.5Kw) | S25711000 |
| 8. | Cover assembly - white..... | P25710603 |

FAULT FINDING

IMPORTANT: Switch OFF the electricity at the mains supply and remove the circuit fuse before removing the cover from the shower while attempting any fault finding inside the unit.

| Problem | Cause | Action |
|---|---|--|
| 1 Shower inoperable, no water flow. | <p>1.1 No mains water supply to shower.</p> <p>1.2 Unit malfunction.</p> | <p>1.1.1 Check if isolating valves are fully open. Check if a blockage in inlet filter or in pipework.</p> <p>1.2.1 Have unit checked. Contact Customer Experience.</p> |
| 2 Water too hot. | <p>2.1 Not enough water flowing through the shower.</p> <p>2.2 Blockage in supply.</p> <p>2.3 Increase in ambient water temperature.</p> | <p>2.1.1 Increase flow rate via temperature control.</p> <p>2.1.2 Blocked shower head — clean or replace blocked sprayplate in shower head.</p> <p>2.2.1 Check if stop valves are fully open. Check if a blockage in inlet filter.</p> <p>2.3.1 Readjust flow rate to give increased flow.</p> <p>2.3.2 Select economy power.</p> |
| 3 Water temperature cycling hot/cool at intervals. | <p>3.1 Heater cycling on temperature limiter.</p> | <p>3.1.1 See Water too hot causes 2.1, 2.2 and 2.3 and their appropriate actions. If it continues, contact Triton Customer Experience.</p> |
| 4 Water too cool or cold. | <p>4.1 Too much flow.</p> <p>4.2 Water pressure below minimum required (see rating label).</p> <p>4.3 Reduction in ambient water temperature.</p> <p>4.4 Interrupted power supply.</p> <p>4.5 Electrical malfunction or safety cut-out operated.</p> | <p>4.1.1 Reduce flow rate via temperature control.</p> <p>4.2.1 Is water supply mains or tank fed?</p> <p>4.2.2 If tank fed, replumb to mains water supply or see 4.2.4.</p> <p>4.2.3 If mains fed, make sure that mains stopvalve is fully open and that there are no other restrictions in the supply while shower is in use, or see 4.2.4.</p> <p>4.2.4 Fit pump to give minimum pressure (see rating label). Contact Customer Experience for advice.</p> <p>4.3.1 Readjust flow rate to give reduced flow.</p> <p>4.3.2 Select HIGH power.</p> <p>4.4.1 Blown fuse or circuit breaker. Check supply. Renew or reset fuse or circuit breaker. If it fails again, consult a qualified electrician.</p> <p>4.4.2 Power cut. Check other appliances and if necessary, contact local Electricity Supply Co.</p> <p>4.5.1 Have unit checked by suitably qualified electrician or contact Triton Customer Experience.</p> |

FAULT FINDING

| Problem | Cause | Action |
|---|---|--|
| 5 Shower varies from normal temperature to cold during use. | 5.1 Water pressure has dropped below minimum required | 5.1.1 Wait until the water pressure resumes to normal. |
| 6 Pressure relief device has operated (water ejected from PRD tube). | 6.1 Blocked shower head. 6.2 Twisted/blocked flexible shower hose. 6.3 Shower head not removed whilst commissioning. | 6.1.1 Clean or replace blocked sprayplate in shower head and then fit new PRD. 6.2.1 Check for free passage through hose. Replace the hose if necessary and fit new PRD. 6.3.1 Fit new PRD. Commission unit with shower head removed. |

Note: Identify cause of operation before fitting new PRD unit.
When fitting a new PRD, follow the commissioning procedure.

It is advised all electrical maintenance/repairs to the shower should be carried out by a suitably qualified person.

In the unlikely event of unit failure other than detailed in the fault finding page, please contact Customer Experience for advice.

Entry Points

Diagram Key:



Water Entry Points



Cable Entry Points

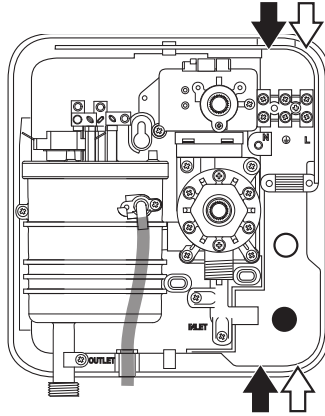

WEEE Directive – Policy Statement

As a producer and a supplier of electric showers, Triton Showers is committed to the protection of the environment via our own environmental policy and compliance with the **WEEE directive**.

Triton Showers is fully registered with the Environment Agency under the following schemes:

Repic: Producer Takeback Scheme (PTS) registration number WEE/EJ3466QV

Valpak: Distributer Takeback Scheme (DTS) registration number DTS-501317-1

All our electric products are labelled accordingly with the crossed out wheeled bin symbol. This indicates, for disposal purposes at end of life, that these products must be taken to recognised collection points, such as local authority sites/local recycling centres; this will be free of any charges. **Do not return to Triton Showers.**



UK SERVICE POLICY

In the event of a product fault or complaint occurring, the following procedure should be followed:

DO NOT REMOVE THE PRODUCT

1. Telephone Customer Experience on **024 7637 2222** having available your details including post code, the model number and power rating of the product, together with the date of purchase and, where applicable, details of the particular fault.
2. If required, the Customer Experience Advisor will arrange for a qualified engineer to call.
3. All products attended to by a Triton service engineer must be installed in full accordance with the Triton installation guide applicable to the product. Every product pack contains an installation guide, however, they can also be downloaded free at www.tritonshowers.co.uk.
4. Our engineer will require local parking and if a permit is required, this must be available to the engineer on arrival at the call.
5. If loft access is required for isolation or to complete a repair, the loft must have a fixed access ladder and be boarded, with appropriate lighting from the access point to and around the repair area.
6. It is essential that you or an appointed representative, who must be over 18 years of age, is present for the duration of the service engineer's visit. If the product is in guarantee you must produce proof of purchase.
7. Where a call under the terms of guarantee has been booked and the failure is not product related (i.e. scaling and furring, incorrect water pressure, pressure relief device operation or electrical/plumbing installation fault) a charge will be made. A charge will also be issued if nobody is at the property when the service engineer calls or adequate parking/permit is not available.
8. If the product is no longer covered by the guarantee an up-front fixed fee will be charged before the site visit.
9. Your receipt must be retained as proof of purchase. Should proof of purchase not be available on an 'in-guarantee' call, or should the service engineer find that the product is no longer under guarantee, the engineer will charge the same fixed price and will request payment prior to departing. If payment is not made on the day an administration charge will be added to the fixed charge.
10. If a debt is outstanding from a previous visit, or from any other Triton purchase, Triton reserves the right to withhold service until the debt has been settled.
11. Triton takes the health, safety and wellbeing of its employees very seriously and expects customers to treat all staff members with respect. Should any employee feel threatened or receive abuse, either verbally or physically, Triton reserves the right to withhold service.

Replacement Parts Policy

In line with AMDEA guidelines, Triton retains functional spares for as long as there is a market for them and in most cases, well beyond. Due to the vast array of product types, the life cycle of products can vary and therefore so can the length of time parts can be supplied. Spare parts can be ordered via our online spare parts store or by telephoning Triton Customer Experience team on **024 7637 2222**. Payment should be made by credit / debit card (excluding American Express or Diners Card). Payment can also be made by pre-payment of a pro-forma invoice, by cheque or postal order.

Telephone orders are based on information given during the call. Before contacting Triton, please verify your requirements using the Triton website or your professional installer. Triton cannot accept liability for incorrect part identification.

Triton Showers
Triton Road
Nuneaton
Warwickshire, CV11 4NR

Triton is a division of Norcros Group (Holdings) Limited

Triton reserve the right to change product specification without prior notice. E&OE. © TRITON SHOWERS 2022

TRITON UK STANDARD GUARANTEE

This guarantee applies only to products installed within the United Kingdom and does not apply to products used commercially. This guarantee does not affect your statutory rights.

With the exception of accessories, Triton guarantee the product against all manufacturing defects for a period of **2 years** (for domestic use only) from the date of purchase, provided that it has been installed by a competent person in full accordance with the fitting instructions.

All accessories such as shower heads, hoses and riser rails carry a **1 year** parts only guarantee against manufacturing defects.

Any part found to be defective during this guarantee period we undertake to repair or replace at our option without charge, so long as it has been properly maintained and operated in accordance with the operating instructions and has not been subject to misuse or damage. This product must not be taken apart, modified or repaired except by a person authorised by Triton.

What is not covered:

1. Breakdown due to:
 - a) use other than domestic use by the property occupants;
 - b) wilful act or neglect;
 - c) any malfunction resulting from the incorrect use or quality of electricity, gas or water or incorrect setting of controls;
 - d) failure to install in accordance with this installation guide.
2. Claims for missing parts once the product has been installed.
3. Repair costs for damage caused by foreign objects or substances.
4. Total loss of the product due to non-availability of parts.
5. Compensation for loss of use of the product or consequential loss of any kind.
6. Call out charges due to an abortive visit or where no fault has been found with the appliance.
7. The cost of repair or replacement of isolating switches, electrical cable, fuses and/or circuit breakers or any other accessories installed at the same time. Replacement of the Pressure Relief Device that only activates when the shower outlet is blocked is also excluded.
8. The cost of routine maintenance, adjustments, overhaul modifications or loss or damage arising therefrom, including the cost of repairing damage, breakdown, malfunction caused by corrosion, furring, frost or exposure to freezing conditions.
9. Callout charges where the water supply cannot be isolated, this includes consequential losses arising from unserviceable supply valves, or inaccessible product or valves located in a loft space without suitable access.

For the latest Terms & Conditions please see:

www.tritonshowers.co.uk/terms

PLEASE NOTE PRODUCT REGISTRATION IS ONLY AVAILABLE TO UNITS PURCHASED & INSTALLED IN THE UK

Customer Experience: **024 7637 2222**

Trade Installer Hotline: **024 7637 8344**

www.tritonshowers.co.uk

E-mail: serviceenquiries@tritonshowers.co.uk

E-mail: technical@tritonshowers.co.uk