

# Rohnson

## Air Fryer

### Instruction Manual

Model: R-2846



## General description

1. Basket
2. Frying Rack
3. Basket Handle
4. Power - On/off icon
5. Time/Temp display
6. Touch screen - 10 cooking function
7. Timer adjustment icon (0-60mins)
8. Temperature adjustment icon (80-200°C)
9. Air inlet
10. Air outlet openings
11. Mains cord
12. Power cord storage

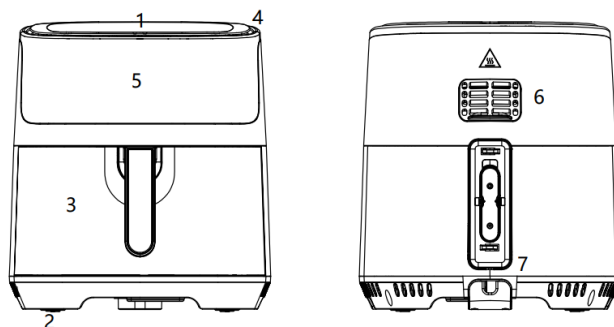

## Important

Please read this manual carefully before any using of the appliance as dangers may occur under incorrect operations.

## Danger

- Do not immerse the housing in water or rinse under the tap due to the electronic and heating components.
- Avoid any liquid entered the appliance to prevent from electric shock or short-circuit.
- Keep all ingredients in the basket to prevent any contact from heating elements.
- Do not cover the air inlet and the air outlet when the appliance is working.
- Fill the pan with oil may cause a fire hazard.
- Do not touch the inside of the appliance while it is operating.

## Warning

- Check if the voltage indicated on the appliance fits the local mains voltage.
- Do not use the appliance if there is any damage to plug, main cord or other parts.
- Do not go to any unauthorized person to replace or fix damaged main cord.
- Keep the appliance and its mains cord out of reach of children.
- Keep the mains cord away from hot surfaces.
- Do not plug in the appliance to an earth wall socket. Always make sure that the plug is inserted into the wall socket properly.
- Do not connect appliance to an external timer switch.
- Do not place the appliance on or near combustible materials such as a tablecloth or curtain.
- Do not place the appliance against a wall or against other appliance. Leave at least 10cm free space on the back and sides and 10cm free space above the appliance.

- Do not place anything on top of the appliance.
- Do not use the appliance for any other purpose than described in this manual.
- Do not let the appliance operate unattended.
- During hot air frying, hot steam is released through the air outlet openings. Keep your hands and face at a safe distance from the steam and from the air outlet openings. Also be careful with hot steam and air when you remove the basket from the appliance.
- Any accessible surfaces may become hot during use.
- Immediately unplug the appliance if you see dark smoke coming out of the appliance. Wait for the smoke emission to stop before you remove the basket from the appliance.

## **Caution**

- Ensure the appliance is placed on a horizontal, even and stable surface.
- This appliance is designed for household use only. It may not be suitable to be safely used in environments such as staff kitchens, farms, motels, and other non-residential environments.
- The guarantee is invalid if the appliance is used for professional or semi-professional purposes or it is not used according to instructions.
- Always unplug the appliance while not using.
- The appliance needs approximately 30 minutes to cool down for handle or cleaning safely.

## **Automatic switch-off**

The appliance has a built-in timer, it will automatically shut down the appliance when count down to zero. You can manually switch off the appliance by pressing off button; it will automatically shut down the appliance in 20 seconds.

## **Before first use**

1. Remove all packaging materials and stickers or labels.
2. Clean the basket and rack with hot water, with some washing liquid and a non-abrasive sponge. These parts are safe to be cleaned in dishwasher.
3. Wipe inside and outside of the appliance with a cloth. And there is no need to fill the basket with oil and frying fat as the appliance works on hot air.

## **Using the appliance**

1. Connect the main plug into an earthed wall socket.
2. Carefully pull the basket out of the air fryer.
3. Put the frying rack into basket.
4. Place the ingredients in the basket.
5. Slide the basket back into the AIR FRYER.

Note: Do not exceed the MAX indication (see section 'settings' in this chapter), as it may affect the quality of the cooked food.

**Caution: Do not touch the basket while the unit is operating and right after the cooking process as it gets very hot. Only hold the basket by the handle.**

6. Do not fill the basket with oil or any other liquid.

7. Finger touched Power on/off knob.

8. Finger touch Menu to choose functions (totally 10 functions).

### Control panel presentation



Temperature range	Time range	Temperature and Time table (°C/Min)										
		The default	Chicken	Pizza	Steak	Cake	Bacon	French Fries	Shrimp	Fish	Chicken wings	Vegetable
80-200°C	0-60MIN	180/15	200/40	185/14	200/10	160/30	185/10	200/18	160/12	160/15	185/40	185/12

**Note:** 10 functions are provided: chicken, pizza, steak, cake, bacon, French fries, shrimp, fish, chicken wings, and vegetable. Finger touch each recipe icon to choose and change the cooking function. More flexible time & temperature setting can be adjusted, and adjustment can be made easily by touching corresponding icons. When you want to adjust time, kindly press the arrow up/down the time icon on screen- Increase/Decrease 1 minute per a press or increase/decrease rapidly in the unit of 1 minute by long pressing. When you want to adjust temperature, kindly press the arrow up/down the temperature icon on screen- Increase/Decrease 5 degrees per a press or increase/decrease rapidly in the unit of 5 degrees by long pressing.

9. After choosing the function, please finger touch Power icon to start cooking.

**Note:** During the hot air frying process, the LED lamp will be running, then if you want to change to another cooking recipe, for example, now you are cooking French fries function, if you want use Cake function, then you just need to press Cake icon. After pressing Pause, if you want change menu or adjust Timer/ Temp., so you can proceed at this period. Then press this button again, the air fryer will continue cooking.

10. Some ingredients require to shake halfway during the preparation time (see section 'settings' in this chapter). By this way, pull the basket out of the appliance by the handle and shake it. Then slide the basket back into the air fryer.

11. Machine will have Auto ready bell after cooking. When you hear bell for 5 times, this means the cooking cycle is finished. Pull the basket out of the appliance and place it on the heat-resistant holder.

**Note:** After the time ends, the heating element stops working, but the fan will continue to run about 20 seconds to blow away the hot air as safety. Finally, the timer bell will ring for 5 times as the ending alarm.

12. Check if the ingredients are ready.

**Note:** If the ingredients are not ready yet, simply slide the basket back into the appliance. Press the temperature control knob to adjust Temperature setting and press the Timer control knob to adjust time setting. And then press the Start knob to run the appliance.

13. To remove ingredients, (e.g., oily meat such as beef, fish or chicken) please use tongs to pick ingredients one by one.

**Note:** Do not turn the basket over. The oil collected on the bottom of the basket will leak onto the ingredients.

14. To remove the excess oil from the ingredients like chips, fries or vegetables, please use tongs to get the food.

Tip: To remove large or fragile ingredients, lift the ingredients out of the basket by a pair of tongs.

15. When a batch of ingredients is ready, the fryer is instantly ready for preparing another batch.

## Settings

This table below will help you to select the basic settings for the ingredients.

**Note:** Keep in mind that these settings are estimated settings only. As ingredients differ in origin, size, shape and brand, we cannot guarantee the best setting for your ingredients. Because the Rapid Air technology heats the air inside the appliance instantly, pulling the basket briefly out of the appliance during hot air frying barely interrupts the process.

## **Tips**

- Smaller ingredients usually require a slightly shorter preparation time than larger Ingredients.
- A larger amount of ingredients only requires a slightly longer preparation time, a smaller amount of ingredients only requires a slightly shorter preparation time.
- Shaking smaller ingredients halfway during the preparation time optimizes the result and can help prevent uneven fried ingredients.
- Add some oil to fresh potatoes and fry your ingredients for another few minutes for a crispy result.
- Do not prepare extremely greasy ingredients such as sausages in the air fryer.
- Snacks that can be prepared in an oven can also be prepared in the air fryer.
- The optimal amount for cooking crispy fries is 500 grams.
- Use pre-made dough to cook snacks quickly and easily. Pre-made dough also requires a shorter preparation time than home-made dough.
- Please use a baking tin or oven dish in the fryer basket if you want to bake a cake or quiche or if you want to fry fragile ingredients or filled ingredients.
- You can also use the air fryer to reheat ingredients. To reheat ingredients, set the temperature to 150°C for up to 10 minutes.

	Min-Max (g)	Time (Min)	Temp °C	Shake	Remark
French fries					
Thin frozen fries	300-700	9-16	200	Y	
Thick frozen fries	300-700	11-20	200	Y	
Home-made fries (8X8mm)	300-800	10-16	200	Y	Add 1/2 tbsp of oil
Homemade potato wedges	300-800	18-22	180	Y	Add 1/2 tbsp of oil
Home-made potato cubes	300-750	12-18	180	Y	Add 1/2 tbsp of oil
	250	15-18	180	Y	
Potato gratin	500	15-18	200	Y	
Steak	100-500	8-12	180		
Meat chops	100-500	10-14	180		
Hamburger	100-500	7-14	180		
Sausage roll	100-500	13-15	200		
Drumsticks	100-500	18-22	180		
Chicken breast	100-500	10-15	180		
Snacks					
Spring rolls	100-400	8-10	200	Y	Use oven-ready
Frozen chicken nuggets	100-500	6-10	200	Y	Use oven-ready
Frozen fish fingers	100-400	6-10	200		Use oven-ready
Frozen bread crumbed	100-400	8-10	180		Use oven-ready
Stuffed vegetables	100-400	1-10	160		
Cake	300	20-25	160		Use baking tin
Quiche	400	20-22	180		Use baking tin/oven dish
Muffins	300	15-18	200		Use baking tin
Sweet snacks	400	1-20	160		Use baking tin/oven dish

#### Making home-made fries

To make home-made fries, follow the steps below:

1. Peel and slice the potatoes.
2. Wash the potato sticks thoroughly and dry them with kitchen paper.
3. Pour 1/2 tablespoon of olive oil in a bowl, put the sticks on top and mix until the sticks are coated with oil.
4. Remove the sticks from the bowl with your fingers or a kitchen utensil so that excess oil stays behind in the bowl. Put the sticks in the basket.
5. Fry the potato sticks according to the instructions in this chapter.

## Cleaning

Clean the appliance after every use.

Do not clean the frying rack, basket and the inside of the appliance by metal kitchen utensils or abrasive cleaning materials, as this may damage the non-stick coating of them.

1. Unplug the plug from the wall socket to let the unit cool down.

**Note:** Remove the basket to let the fryer cool down more quickly.

2. Wipe the outside of the appliance with a moist cloth.

3. Clean the frying rack and basket with hot water, use some liquid soap and a non-abrasive sponge.

You can remove any remaining dirt by using a liquid soap that removes grease.

**Note:** The frying rack and basket are dishwasher-proof.

**Tip:** If dirt is stuck to the basket or the bottom of the basket, fill the basket with hot water put some dishwashing liquid soap. Put the frying rack in the basket and let them soak for about 10 minutes.

4. Clean the inside of the appliance with hot water and non-abrasive sponge.

5. Clean the heating components with a cleaning brush to remove any food residues.

## Storage

1. Unplug the appliance and let it cool down thoroughly.

2. Make sure all parts are clean and dry.

## Troubleshooting

Problem	Possible cause	Solution
The AIR FRYER does not work.	The appliance is not plugged in.	Put the mains plug in an earthed wall socket.
	You haven't pressed the start button.	Press the start/power button after you set the temp&time or choose the quick recipe.
The ingredients fried with the AIR FRYER are not done.	The amount of ingredients in the basket is too big.	Put smaller batches of ingredients in the basket. Smaller batches are fried more evenly.
	The set temperature is too low.	Set the temperature to the required Temperature setting.
The ingredients are fried unevenly in the AIR FRYER.	Certain types of ingredients need to be shaken halfway through the preparation time	Ingredients that lie on top of or across each other (e.g. fries) need to be shaken halfway through the preparation time.
Fried snacks are not crispy when they come out of the AIR FRYER.	You used a type of snacks meant to be prepared in a traditional deep fryer.	Use oven snacks or lightly brush some oil onto the snacks for a crisper result.
I can't slide the basket into the appliance properly.	There are too many ingredients in the basket.	Do not fill the basket beyond the MAX indication.

White smoke comes out from the appliance.	You are preparing greasy ingredients.	When you fry greasy ingredients in the AIR fryer, a large amount of oil will leak into the basket. The oil produces white smoke and the basket may heat up more than usual. This does not affect the appliance or the end result.
	The basket still contains grease residues from previous use.	White smoke is caused by grease heating up in the basket. Make sure you clean the basket properly after each use.
Fresh fries are fried unevenly in the AIR FRYER.	You did not use the right potato type.	Use fresh potatoes and make sure that they stay firm during frying.
	You did not rinse the potato sticks properly before you fried them.	Rinse the potato sticks properly to remove starch from the outside of the sticks.
Fresh fries are not crispy when they come out of the AIR FRYER.	The crispiness of the fries depends on the amount of oil and water in the fries.	Make sure you dry the potato sticks properly before you add the oil.
		Cut the potato sticks smaller for a crispier result.
		Add slightly more oil for a crispier result.



**IMPORTANT INFORMATION FOR CORRECT DISPOSAL OF THE PRODUCT IN ACCORDANCE WITH EC DIRECTIVE 2012/19/EU.**

At the end of its working life, the product must not be disposed of as urban waste. It must be taken to a special local authority differentiated waste collection center or to a dealer providing this service. Disposing of a household appliance separately avoids possible negative consequences for the environment and health, deriving from inappropriate disposal and enables the constituent materials to be recovered to obtain significant savings in energy and resources. As a reminder of the need to dispose of household appliances separately, the product is marked with a crossed-out wheeled dustbin.