

FH1163 FH1363

MULTIFRY

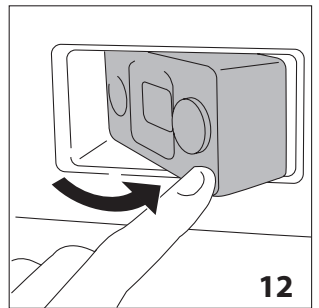

De'Longhi

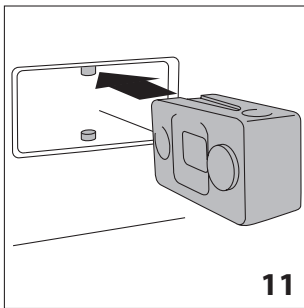
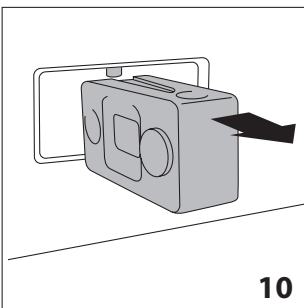
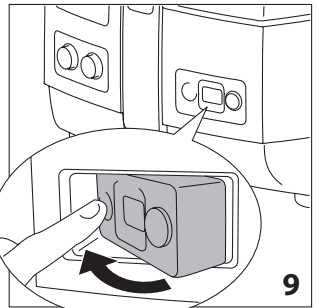
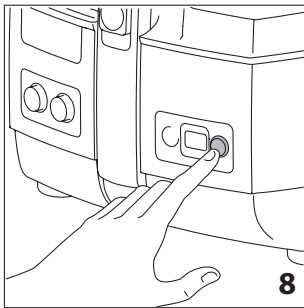
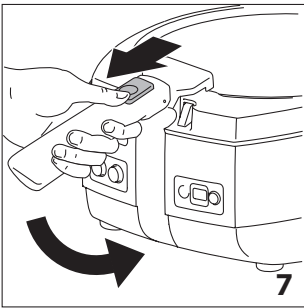
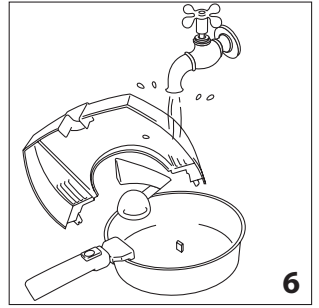
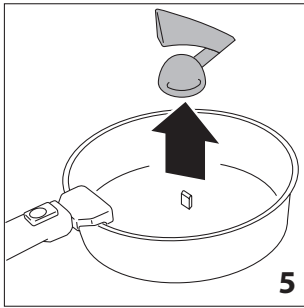
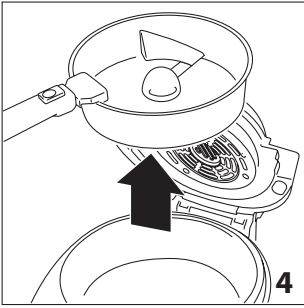
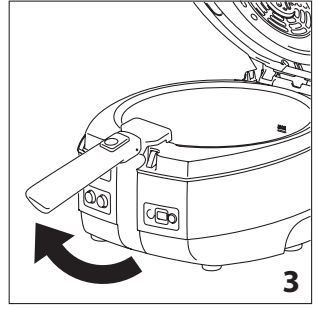
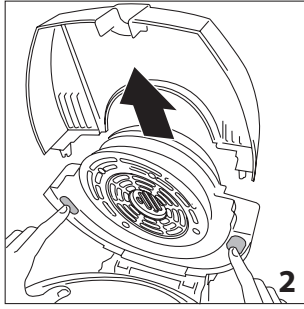
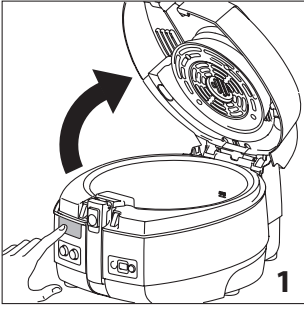
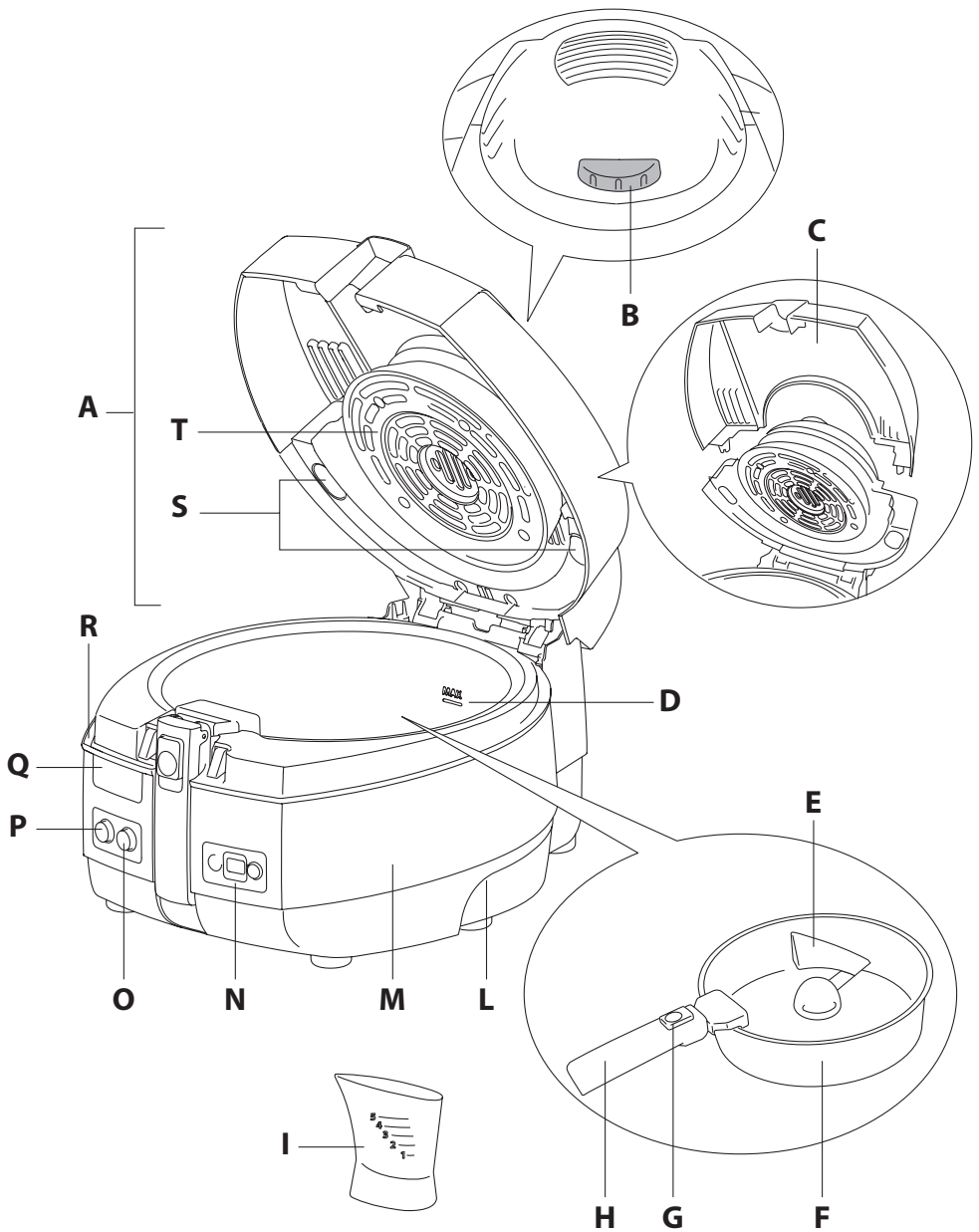



EN

page 5

FR

page 11

ES

pág. 17

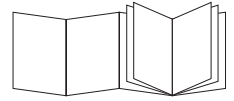

For more recipes:
(free download)



De'Longhi Recipes

multifry.delonghi.com

IMPORTANT SAFEGUARDS

The use of all electrical appliances implies the observance of some fundamental rules.

1. Read all instructions.
2. Do not touch hot surfaces. Use handles or knobs.
3. To protect against electrical shock do not immerse cord, plugs, or (state specific part or parts in question) in water or other liquid.
4. Close supervision is necessary when any appliance is used by or near children.
5. Unplug from outlet when not in use and before cleaning. Allow to cool before putting on or taking off parts.
6. Do not operate any appliance with a damaged cord or plug or after the appliance malfunctions or has been damaged in any manner. Return appliance to the nearest authorized service facility for examination, repair, or adjustment.
7. The use of accessory attachments not recommended by the appliance manufacturer may cause injuries.
8. Do not use outdoors (this item may be omitted if the product is specifically intended for outdoor use).
9. Do not let cord hang over edge of table or counter, or touch hot surfaces.
10. Do not place on or near a hot gas or electric burner, or in a heated oven.
11. Extreme caution must be used when moving an appliance containing hot oil or other hot liquids.
12. Always attach plug to appliance first, then plug cord into the wall outlet. To disconnect, turn any control to 'off', then remove plug from wall outlet.
13. Do not use appliance for other than intended use.

SAVE THESE

INSTRUCTIONS

THIS PRODUCT IS INTENDED FOR HOUSHOLD USE ONLY

WARNINGS

- Never immerse the appliance in water.
- When in operation, accessible external surfaces and the lid could become very hot. Always use the handgrip, handles and buttons.
Use oven gloves if necessary.
- This electrical appliance operates at high temperatures which could cause burns.
- Do not preheat the appliance when empty.
- Do not use the appliance without food, you might damage it.
- While in operation, the appliance becomes hot.
DO NOT LEAVE WITHIN REACH OF CHILDREN.
- Move the appliance by the handles only.
Never move the appliance using the bowl handgrip.
- Never leave the power cable hanging from the edge of the surface the appliance is resting on where it could be grasped by a child or get in the way of the user.
- Hot steam may come out of the vents. Take great care!
- Never locate the appliance near sources of heat.
- The bowl fits automatically onto the central pin.
To avoid damage, never rotate it manually to find the right position.
- Never insert anything into the ventilation openings.
Make sure they are unobstructed.
- Do not fill the bowl with liquid above the MAX level (D).
- Do not put more oil in the bowl than the maximum level on the oil measure (level 5).
- Before using the appliance for the first time, remove any paper and other material inside the oven such as protective cardboard, booklets, plastic bags, etc.
- Before using the appliance for the first time, wash the bowl, paddle and lid in hot water and washing up liquid.
At the end of the operation, dry all components thoroughly and remove any water left in the bottom of the bowl.
- It is normal for the appliance to give off a "new" smell when used for the first time. Ventilate the room.
- The appliance must be kept at a distance of at least 7.8 in from the mains power socket to which it is connected.

TECHNICAL DATA

	FH1163	FH1363
size (LxHxD):	15.5 x 12.8 x 10.6in	15.5 x 12.8 x 11.4in
weight:	10.6 lbs	11 lbs

For further information, see the rating plate on the appliance.

Frozen Potatoes:

2.6lbs (FH1163)

3.3lbs (FH1363)

Total Liquid Capacity:

52 oz (FH1163)

68 oz (FH1363)

DESCRIPTION OF APPLIANCE

A	Lid
B	Power level
C	Removable viewing window
D	Maximum level MAX
E	Paddle
F	Ceramic coated bowl
G	Handgrip slide
H	Bowl handgrip
I	Oil measurer (level from 1 to 5)
L	Handle for lifting the appliance
M	Appliance body
N	Removable timer
O	Bottom heating element button
P	ON/OFF button with light
Q	Lid open button
R	Condensate tray
S	Viewing window release buttons
T	Hot air discharge grille

SETTING UP THE APPLIANCE

i Please note: Before using the appliance for the first time, wash the bowl (F), paddle (E) and removable viewing window (C) in hot water and neutral washing up liquid.

Proceed as follows:

- Open the lid (A) by pressing button (Q) (fig. 1).
- Release the removable viewing window (C) by pressing the two buttons (S) (fig. 2).
- Lift the bowl handgrip (H) until you hear a “click” (fig. 3).
- Extract the bowl (F) by pulling upwards (fig. 4).
- Extract the paddle (E) from its housing (fig. 5).
- Wash the bowl (F), paddle (E) and removable viewing window (C) (fig. 6).
- At the end of the operation, dry all components thoroughly

and remove any water left in the bottom of the bowl (F).

COOKING WITH THE PADDLE

i Please note: This type of cooking is particularly suitable for cooking potatoes.

- Put the bowl (F) back in the appliance body (M), making sure it is correctly positioned.
- Lower the bowl handgrip (H) using the slide (G) (fig. 7).
- Insert the paddle (E), making sure it is correctly positioned on the pin at the bottom of the bowl.
- Place the ingredients to be cooked in the bowl (F), respecting the quantities given in the cooking tables/recipes.
- If required by the cooking procedure, add oil, referring to the quantities indicated in the cooking tables/recipes and using the measure (I).
- Close the lid (A).
- Plug the appliance into the mains socket.
- Adjust the power level (B) to the required position (see cooking tables/recipes).
- If required by the cooking procedure, press the bottom heating element button (O) (see the cooking tables/recipes).
- Press the ON/OFF button (P). The light in the button comes on. The lower heating element activates immediately. The upper heating element will turn on when the lid is closed.
- Cooking begins.
- Set the cooking countdown by pressing the button on the timer (N) (fig. 8). The minutes set appear on the display.
- Immediately afterwards, the numbers begin to flash. This means the cooking time has begun. The last minute is displayed in seconds.
- If you make a mistake, you can set the new cooking time by holding the button down for more than two seconds. When the display has reset, repeat the operation.
- The timer indicates the end of cooking time with two series of beeps separated by a 20 second gap. To turn off the signal, just press the timer button.

i Please note: the timer does not turn the appliance off.

i Please note: To guarantee best results, the paddle (E) begins to turn a few minutes after cooking begins.

i Please note: During cooking, you can lift up the lid (A) to add ingredients or check cooking progress. Ventilation stops briefly, then starts again when you close the lid.

i Please note: If the ON/OFF button is on, extracting the bowl turns the appliance off. It starts working again when the bowl is reinserted.

- At the end of cooking, if the bottom heating element (O)

has been used, press the bottom heating element button again to turn it off.

- Turn the appliance off by pressing the ON/OFF button (P) again;

COOKING WITHOUT THE PADDLE

 **Please note:** This type of cooking is particularly suitable for cooking desserts, cakes, pastries and pizzas.

- Put the bowl (F) back in the appliance (M), making sure it is correctly positioned.
- Lower the bowl handgrip (H) using the slide (G) (fig. 7).
- Place the ingredients to be cooked in the bowl (L), respecting the quantities given in the cooking tables/recipes.
- If required by the cooking procedure, add oil, referring to the quantities indicated in the cooking tables/recipes and using the measure (I).
- Close the lid (A).
- Plug the appliance into the mains socket.
- Adjust the power level (B) to the required position (see cooking tables/recipes).
- If required by the cooking procedure, press the bottom heating element button (O) (see the cooking tables/recipes).
- Press the ON/OFF button (P). The light in the button comes on. The lower heating element activates immediately. The upper heating element will turn on when the lid is closed.
- Cooking begins.
- Set the cooking time by pressing the button on the timer (N) (fig. 8). The minutes set appear on the display.
- Immediately afterwards, the numbers begin to flash. This means the cooking time has begun. The last minute is displayed in seconds.
- If you make a mistake, you can set the new cooking time by holding the button down for more than two seconds. When the display has reset, repeat the operation.
- The timer indicates the end of cooking time with two series of beeps separated by a 20 second gap.
To turn off the signal, just press the timer button.

 **Please note:** The timer does not turn the appliance off.

 **Please note:** When cooking without the paddle, the pin on the bottom of the bowl still turns a few minutes after cooking begins.

 **Please note:** During cooking, you can lift up the lid (A) to add ingredients or check cooking progress.

Ventilation stops briefly, then starts again when you close the lid.

 **Please note:** If the ON/OFF button is on, extracting the

bowl turns the appliance off. It starts working again when the bowl is reinserted.

- At the end of cooking, if the bottom heating element (O) has been used, press the bottom heating element button again to turn it off.
- Turn the appliance off by pressing the ON/OFF button (P) again;

EXTRACTING THE TIMER

- To extract the timer (N) from its housing, press the left side of the display, then turn (fig. 9) and pull off (fig. 10).
- To put the timer back, thread it onto the pins in the housing and push as far as it will go until it catches (fig. 11), then turn as shown in fig. 12.

 **Please note:** To replace the timer battery, contact the manufacturer's authorised Customer Experience.

CLEANING AND MAINTENANCE

 **Danger!** Before cleaning the appliance, always unplug from the mains socket and allow to cool.

Never immerse the appliance in water and never place under running tap water.

If water gets into the appliance, it could cause electric shock.

- Wash the bowl (F), paddle (E) and viewing window (C) thoroughly with hot water and neutral washing up liquid. The bowl is dishwasher safe. Frequent washing could reduce the properties of the ceramic coating.
- Clean the hot air discharge grille (T) without removing it.

 **Please note:** *Do not use sharp, abrasive or metallic utensils to remove food from the bowl as this can damage the ceramic coating. Clean with a soft cloth and neutral detergent only.*

TROUBLESHOOTING

Fault	Cause/solution
The appliance does not heat up	The thermal cutout may have tripped. Contact the manufacturer's Customer Experience (the device must be replaced).
The bowl is not positioned correctly and the appliance does not work	Position the bowl correctly
The lid is not properly closed and the appliance does not work	Close the lid
The food is raw at the bottom	Make sure you have pressed the bottom heating element button (0)
The paddle (E) does not turn	Wait for a few minutes after cooking begins

COOKING TABLES

Potatoes

Recipe	Type	Quantity	Oil	Cooking time (min)		Paddle	Bottom heating element	Power Level
				FH1163	FH1363			
Standard potatoes cut to 1x1cm thick chips	Fresh	3.7 lbs (*)	level 5	-	40-43	YES	ON	4
		3.3 lbs (*)	level 4	37-40	37-40	YES	ON	4
		2.8 lbs (*)	level 3	32-35	35-38	YES	ON	4
		2.2 lbs (*)	level 2	27-30	25-28	YES	ON	4
		1.7 lbs (*)	level 1	23-25	21-23	YES	ON	4
	Frozen	3.3 lbs	without	-	42-45	YES	ON	4
		2.8 lbs	without	33-36	35-38	YES	ON	4
		2.2 lbs	without	27-30	29-32	YES	ON	4
		1.7 lbs	without	24-26	24-26	YES	ON	4
		1.1 lbs	without	18-20	18-20	YES	ON	4
Roast potatoes	Fresh	2.2 lbs	level 3	35	35	YES	ON	4
Potato wedges	Frozen	2.2 lbs	without	30	32	YES	ON	4
New potatoes	Frozen	2.2 lbs	without	38	40	YES	ON	4
Croquettes	Frozen	1.7 lbs	without	24	26	YES	ON	4

(*) un-peeled potato weight

Meat - poultry

Recipe	Type	Quantity	Oil	Cooking time (min)		Paddle	Bottom heating element	Power Level	Tips
				FH1163	FH1363				
Chicken nuggets	Frozen	1.7 lbs	without	18	18	YES	ON	4	-
Chicken drumsticks	Fresh	1.5 lbs	without	35	35	NO	OFF	4	turn 2-3 times
Chicken breast	Fresh	3 pcs	without	15	15	NO	ON	4	-
Braised veal	Fresh	1.25 lbs	level 2	25	25	YES	ON	4	-
Veal chops	Fresh	3 pcs	without	25	28	NO	OFF	4	turn over after 15 min
Veal spare ribs	Fresh	2.5 lbs	without	35	38	NO	OFF	4	turn 2-3 times
Kebabs	Fresh	5-6 pieces	without	22	25	NO	OFF	4	turn 2-3 times
Hamburger	Fresh	4 pcs	without	25	28	NO	OFF	4	turn over after 15 min
Meatballs	Fresh	1 lbs	without	25	25	YES	ON	4	-

Fish - shellfish

Recipe	Type	Quantity	Oil	Cooking time (min)		Paddle	Bottom heating element	Power Level
				FH1163	FH1363			
Fish fingers	Frozen	18 pcs	without	20	23	NO	ON	4
Salmon steak	Fresh	27 oz	without	20	20	NO	ON	3
Salmon fillet	Fresh	26 oz	without	15	18	NO	ON	3
Scallops	Fresh	4 pcs	without	17	20	NO	OFF	3
Cuttlefish	Fresh	8 pcs	level 1	20	20	NO	ON	3
Tiger prawns	Fresh	1.3 lbs	level 1	20	20	YES	ON	3
Prawns	Fresh	1.7 lbs	level 1	20	20	YES	ON	3

Vegetables

Recipe	Type	Quantity	Oil	Cooking time (min)		Paddle	Bottom heating element	Power Level
				FH1163	FH1363			
Zucchini	Fresh	4 cups	level 5	20-25	20-25	YES	ON	4
Eggplant	Fresh	4 cups	level 3	20-25	20-25	YES	ON	4
Mushrooms	Fresh	4 cups	level 2	15-20	15-20	YES	ON	4
Asparagus	Fresh	6 cups	level 5	25-30	25-30	YES	ON	4

Snacks - Frozen

Recipe	Type	Quantity	Oil	Cooking time (min)		Paddle	Bottom heating element	Power Level	Tips
				FH1163	FH1363				
Pizza	Fresh	9.5 in	level 1	32	35	NO	ON	2	oil the pan and turn it through 180° after 20 min
	Frozen	9 in	without	20	25	NO	ON	2	turn through 180° after 15 min
Savoury pies and quiches	Fresh	9 in	without	23	27	NO	ON	3	use greaseproof paper and turn through 180° after 15 min
	Frozen	9 in	without	45	50	NO	ON	2	use greaseproof paper and turn through 180° after 30 min
Mini-pizzas	Frozen	14 pcs	without	20	20	NO	ON	3	use greaseproof paper
Mini-savouries	Frozen	14 pcs	without	25	25	NO	ON	3	use greaseproof paper
Paella	Frozen	1.3 lbs	without	15	15	YES	ON	4	mix once
Gnocchi alla sorrentina	Frozen	1 lbs	without	13	13	YES	ON	4	mix once
Onion rings	Frozen	12/15 pcs	without	15	15	NO	ON	4	spread evenly on the bottom of the bowl

Desserts, cakes and pastries

Recipe	Type	Quantity	Oil	Cooking time (min)		Paddle	Bottom heating element	Power Level	Tips
				FH1163	FH1363				
Tarts	Fresh	9 in	without	50	50	NO	ON	2	butter and flour the pan and turn the bottom heating element off after 40 min
Brioches	Frozen	4 pcs	without	35	35	NO	ON	2	use greaseproof paper and turn through 180° after 12-13 min
Biscuits	Fresh	8 pcs	without	18	18	NO	ON	3	use greaseproof paper and turn through 180° after 15 min
Fruit	Fresh	2 cups	without	18	18	NO	ON	4	-