



DAEWOO

POWER PRODUCTS

GD SERIES

Gasoline Generator

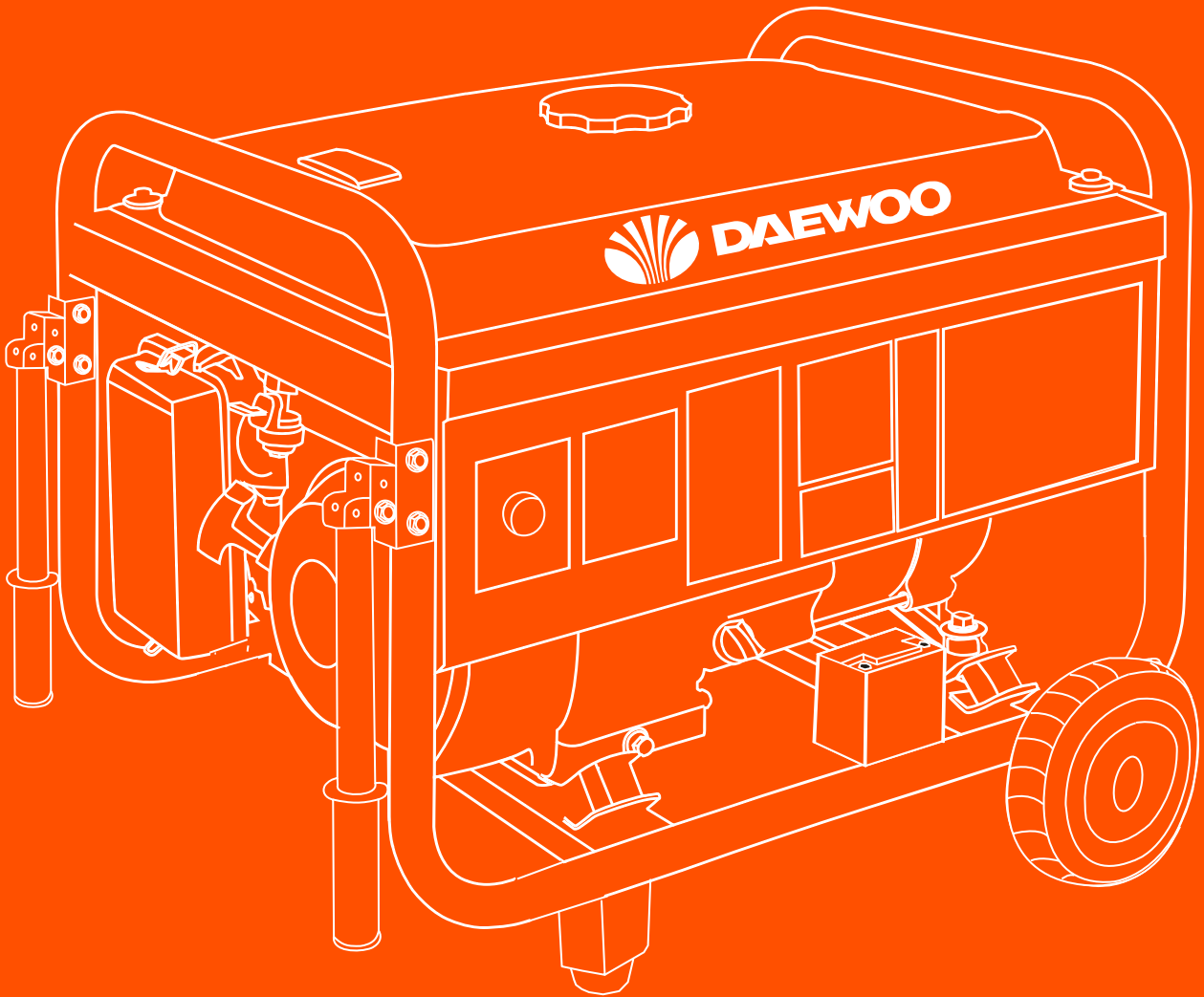

USER'S MANUAL

www.daewoopowerproducts.com

Manufactured under license of Daewoo International Corporation, Korea

INDEX

1. SAFETY	3
2. COMPONENT IDENTIFICATION	4
3. CONTROLS	5
4. GENERATOR USE	6
5. PRE-OPERATION CHECK	10
6. STARTING/STOPPING THE ENGINE	12
7. MAINTENANCE	13
8. TRANSPORTING/STORAGE	17
9. TROUBLESHOOTING	20
10. WINING DIAGRAM	21
11. SPECIFICATIONS	23
12. GENERATOR ASSEMBLY AND MOUNTING	27
WARRANTY	28

Thank you for purchasing a generator. We want to help you get the best results from your new generator and to operate it safely.

This manual contains the information on how to do that; please read it carefully.

All information and specifications in this publication is based on the latest product information available at the time of printing. We reserve the right to make changes at any time without notice and without incurring any obligation. No part of this publication may be reproduced without written permission.

This manual should be considered a permanent part of the generator and should remain with it if it is resold.

Safety Messages

Your safety and the safety of others are very important. We have provided important safety messages in this manual and on generator. Please read these messages carefully.

A safety message alerts you to potential hazards that could hurt you or others, Each safety message is preceded by a safety alert symbol and one of three words: DANGER, WARNING, or CAUTION.

These mean:

DANGER!

You WILL be KILLED or SERIOUSLY HURT if you don't follow instructions.

WARNING!

You CAN be KILLED or SERIOUSLY HURT if you don't follow instructions.

CAUTION!

You CAN be HURT if you don't follow instructions.

Damage Prevention Messages

Other important messages are preceded by the word NOTICE.

This word means:

NOTICE!

Your generator or other property could be damaged if you don't follow instructions.

The purpose of these messages is to help prevent damage to your generator, other property, or the environment.

1. SAFETY

The generators are designed to give safe and dependable service if operated according to instructions. Read and understand this owner's manual before operating your generator. You can help prevent accidents by being familiar with your generator's controls, and by observing safe operating procedures.

Operator Responsibility

- Know how to stop the generator quickly in case of emergency.
- Understand the use of all generator controls, output receptacles. And connections.
- Be sure that anyone who operates the generator receives proper instruction. Do not let children operate the generator without parental supervision. Keep children and pets away from the area of operation.
- Place the generator on a firm, level surface and avoid loose sand or snow. If the generator is tilted or overturned, fuel spillage may result. Also. If the generator is overturned or sinks into a soft surface, sand, dirt, or water may enter the generator.

Carbon Monoxide Hazards

- Exhaust Contains poisonous carbon monoxide. a colorless and odorless gas Breathing exhaust can cause loss of consciousness and may lead to death.
- If you run the generator in an area that is confined or ever partially enclosed. The air you breathe could contain a dangerous amount of exhaust gas. To keep exhaust Gas from building up, provide adequate ventilation.

Electric Shock Hazards

- The generator produces enough electric power to cause a serious shock or electrocution if misused.
- Using a generator electrical appliance in wet conditions, such as rain or snow, or near a pool or sprinkler system, or when your hands are wet: could result in electrocution. Keep the generator dry.
- If the generator is stored outdoors, unprotected from the weather, check all electrical components on the control panel. before each use. Moisture or ice can cause a malfunction or short circuit in electrical components which could result in electrocution.
- Do not connect to a building's electrical system unless an isolation switch has been installed by a qualified electrician.

Fire and Burn Hazards

- The exhaust system gets hot enough to ignite some materials.
- * Keep the generator at least 1 meter (3 feet) away from buildings and other equipment during operation.
- * Do not enclose the generator in any structure .
- * Keep flammable materials away from the generator.
- The muffler becomes very hot during operation and remains hot for a while after stopping the engine. Be careful not to touch the muffler while it is hot. Let the engine cool before storing the generator indoors-.

- Gasoline is extremely flammable and is explosive under certain conditions. Do not Smoke or allow flames or sparks where the generator is refueled or where gasoline is stored. Refuel in a well-ventilated area with the engine stopped.
- Fuel vapors extremely flammable and may ignite after the engine has started. Make sure that any spilled fuel has been wiped up before starting the generator.

2. COMPONENT IDENTIFICATION

NOTE!

Diagrams may vary according to the types.

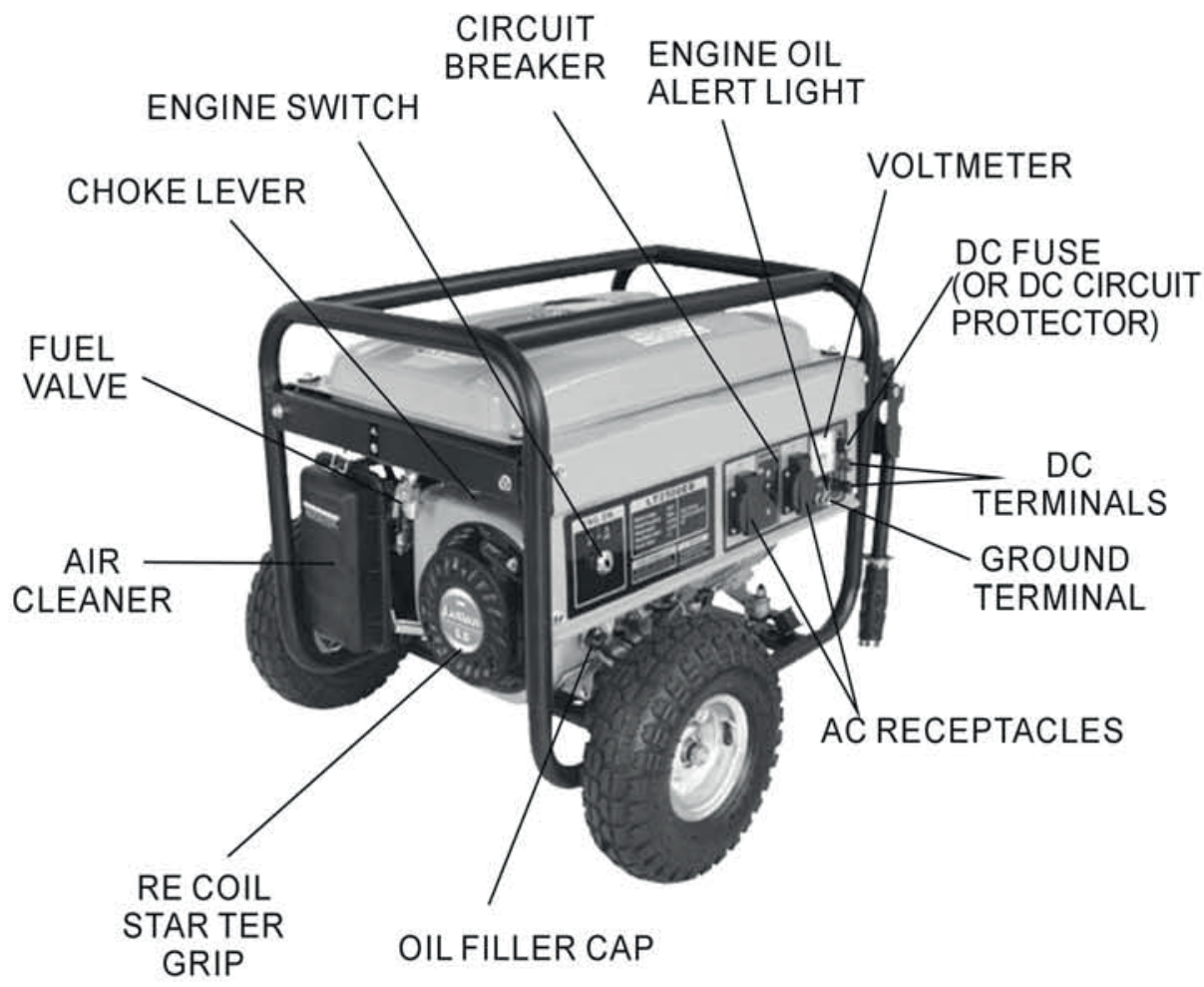

3. CONTROLS

1) Engine Switch

To start and stop the engine.

Switch position:

OFF: To Stop the engine. Key can be removed/inserted.

ON: To run the engine after starting.

START: To start the engine by turning the starter motor.

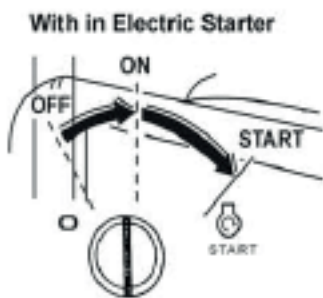

With out Electric Starter

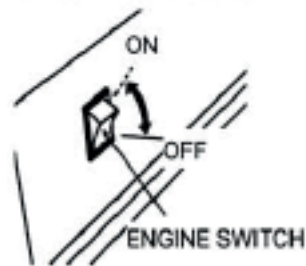

Return the key to the ON position once the engine has started. Do not use the starter for more than 5 seconds at a time. If the engine fails to start, release the switch and wait 10 seconds before operating the starter again.

2) Recoil Starter

To start the engine, pull the starter grip lightly until resistance is felt, then pull briskly.

NOTICE!

Do not allow the starter to snap back against the engine. Return it gently to prevent damage to the starter.

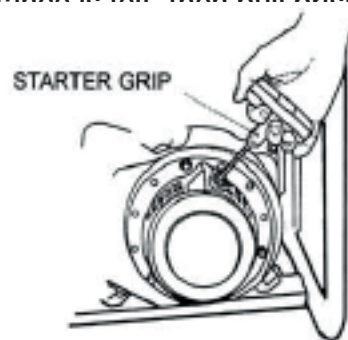

3) Fuel Valve

The fuel valve is located between the fuel tank and carburetor. When the valve lever is in the ON position, fuel is allowed to flow from the fuel tank to the carburetor. Be sure to Return the

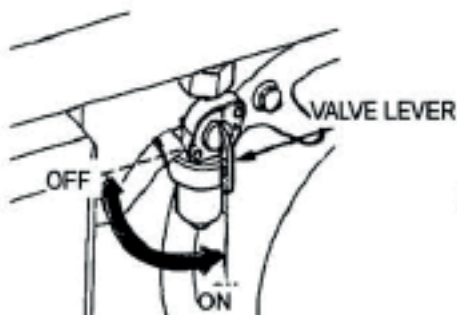

4) Choke

4. Choke

The choke is used to provide an enriched fuel mixture when starting a cold engine. It can be opened and closed by operating the choke lever or choke rod manually. Move the lever or the rod to the CLOSE position to enrich the mixture.

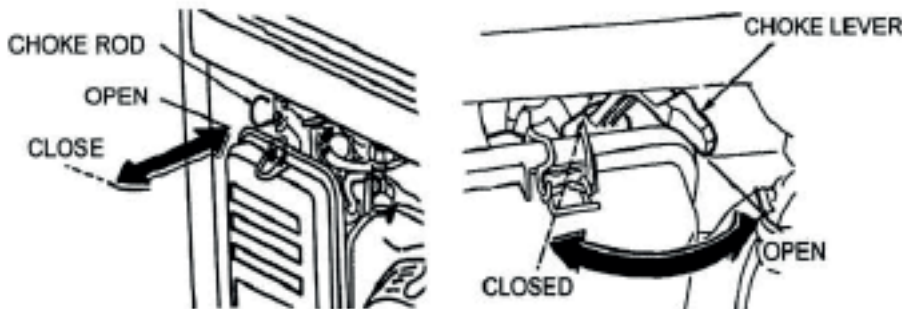

5) Circuit Breaker

The circuit breaker will automatically switch OFF if there is a short circuit or a significant overload of the generator at the receptacle. If the circuit breaker is switched OFF automatically, check that the appliance is working properly and does not exceed the rated load capacity of the circuit before switching the circuit breaker ON again. The circuit breaker may be used to switch the generator power ON or OFF.

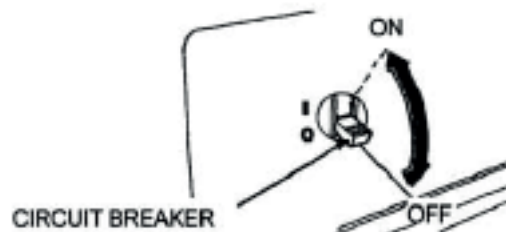

6) Ground Terminal

The generator ground terminal is connected to the panel of the generator, the metal non-current carrying parts of the generator, and the ground terminals of each receptacle. Before using the ground terminal, consult a qualified electrician, electrical inspector or local agency having jurisdiction for local codes or ordinances that apply to the intended use of the generator.

7) Oil Alert System

The oil alert system is designed to prevent engine damage caused by an insufficient amount of oil in the crankcase. Before the oil level in the crankcase can fall below a safe limit the oil alert system will automatically shut down the engine (the engine switch will remain in the ON position). The oil alert system shuts down the engine and the engine will not start. If this occurs, first check engine oil.

4. GENERATOR USE

1) Connections to a Building's Electrical System

Connections for standby power to a building's electrical system must be made by a qualified electrician. the connection must isolate the generator power from utility power and must comply with all applicable laws and electrical codes.

WARNING!

Improper connections to a building's electrical system, can allow electrical current from the generator to feedback into the utility lines, Such feedback may electrocute utility company workers or others who contact the lines during a power outage. Consult the utility company or a qualified electrician.

CAUTION!

Improper connections to a building's electrical system can allow electrical current from the utility company to feedback into the generator. When utility power is restored, the generator may explode, burn, or cause fires In the building's electrical system.

2) Ground System

To prevent electrical shock from fowly appliances, the generator should be grounded. Connect a length of heavy wire between the ground terminal and the ground source. The generators have a system ground that connects generator frame components to the ground terminals, in the AC output receptacles. The system ground is not connected to the AC neutral wire. If the generates is tested by a receptacle tester. it will not show the same ground circuit condition as tor a home receptacle.

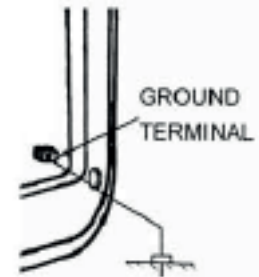

Special Requirements

there may be Federal or State Occupational Safety and Health Administration (OSHA) regulations, local codes, or ordinances that apply to the intended use of the generator Please consult a qualified electrician, electrical inspector, or the local agency having jurisdiction.

- In some areas, generators are required to be registered with local utility companies.
- If the generator is used at a construction site, there may be additional regulations which must be observed

3) AC Applications

Before connecting an appliance or power to the generator:

- Make sure that it is in good working order. Faulty appliances or power cords can create a potential for electrical shock.
- If an appliance begins to operate abnormally, becomes sluggish or stops suddenly. turn it off immediately. Disconnect the appliance, and determine whether the problem is the appliance, or if the rated load capacity of the generator has been exceeded.
- Make sure that the electrical, rating of the tool or appliance does not exceed that of the generator. Never exceed the maximum power rating of the generator. Power levels between rated and maximum may be used for no more than 30 minutes.

NOTICE!

Substantial overloading will switch off the circuit breaker. Exceeding the time limit for maximum power operation or slightly overloading the generator may not switch the- circuit breaker OFF. but

will shorten the service life of the generator.
Limit operation requiring maximum power to 30 minutes.

For continuous- operation, do not exceed the rated power .

In either case. the total power requirements (VA) of all appliances connected must be considered. Appliance and power tool manufacturers usually list rating information near the model number or serial number.

4) AC Operation

- ①. Start the engine
- ②. Switch the AC circuit breaker ON
- ③. Plug in the appliance

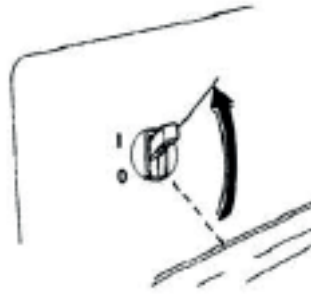

Most motorized appliances require more than their rated wattage for startup.

Do not exceed the current limit specified for any one receptacle. if an overloaded circuit causes the AC circuit breaker to switch OFF, reduce the electrical load on the circuit, wait a few minutes and then reset the circuit breaker.

5) DC OPERATION

DC Terminals

The DC terminals may ONLY be used for charging 12 volt automotive type batteries.

The terminals are colored red to identify the positive (+) terminal and black to identify the negative (-) terminal. the battery must be connected to -he-generator DC terminals with the proper polarity (battery positive to generator red terminal and battery negative id the generator black terminal).

With DC Circuit Protector

With DC Fuse

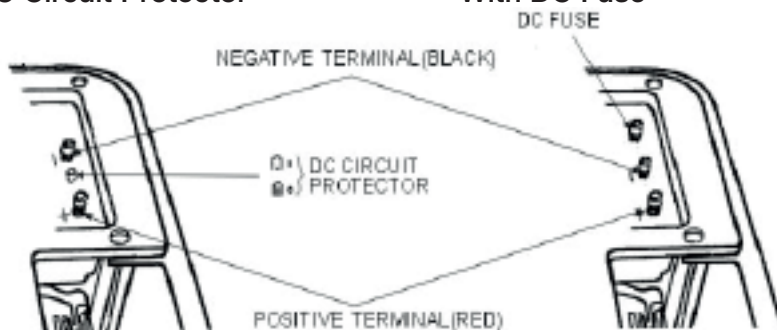

DC circuit protector (or DC Fuse)

The DC circuit protector(or DC Fuse) automatically shuts off the DC battery.

Charging circuit when the DC circuit is overloaded, when there is a problem with the battery, or the connections between the battery and the generator are improper.

The indicator inside the DC circuit protector button will pop out to show that the DC circuit protector has switched off. Wait a few minutes and push the button in to reset the DC circuit protector.

Connecting the battery cables:

- ①. Before connecting charging cables to a battery that is installed in a vehicle Disconnect the vehicle's grounded battery cable.

WARNING!

The battery gives off explosive gases; keep sparks, flames and cigarettes away, Provide adequate ventilation when charging causing batteries.

- ②. Connect the positive (+) battery cable to the battery positive (+) terminal.
- ③. Connect the other end of the positive(+) battery cable to the generator
- ④. Connect the negative (-) battery cable to the battery negative (-) terminal.
- ⑤. Connect the other end of the negative(-) battery cable to the generator
- ⑥. Start the generator.

NOTICE!

Do not start the vehicle while the battery charging cables are connected and the generator is running. The vehicle or the generator may be damaged.

An overloaded DC circuit will fuse the DC fuse, if this happens, replace fuse. An overloaded DC, excessive current draw by the battery, or a wiring problem will trip the DC circuit protector (PUSH button extends out). If this happens, wait a few minutes before pushing in the circuit protector to resume operation. If the circuit protector continues to go OFF. discontinue charging and see your authorized generator dealer.

Disconnecting the battery cables:

- ①. Stop the engine,
- ②. Disconnect the negative (-) battery cable from the generator negative (-)terminal.
- ③. Disconnect the other end of the negative (-) battery cable from the battery negative (-)terminal.
- ④. Disconnect the positive(+) battery cable from the generator positive (+)terminal,
- ⑤. Disconnect the other end of the positive(+)battery cable to the battery positive(+) terminal.
- ⑥. Connect the vehicle ground cable to battery negative (-) terminal.

⑦. Reconnect the vehicle grounded battery cable.

6) High Altitude Operation

At high altitude, the standard carburetor air-fuel mixture will be excessively rich. Performance will decrease, and fuel consumption will increase.

High altitude performance can be improved by installing a smaller diameter main fuel jet in the carburetor and readjusting the pilot screw, If you always operate the engine at altitudes higher than 5000 feet (1500 meters) above sea level, have an authorized generator dealer perform this carburetor modification.

Even with suitable carburetor jetting, engine horsepower will decrease approximately 3.5% for each 1000 foot (300 meter) increase in altitude. The effect of altitude on horsepower will be greater than this if no carburetor modification is made.

NOTICE!

If a engine jetted for high altitude is used at a lower altitude, the lean air fuel mixture will reduce performance and may overheat and seriously damage the engine.

5. PRE-OPERATION CHECK

1) Engine oil

NOTICE!

Engine oil is a major factor affecting engine performance and service life. Non detergent and 2-stroke engine oils will damage the engine and are not recommended.

Check the oil level BEFORE EACH USE with the generator on a level surface with the engine stopped.

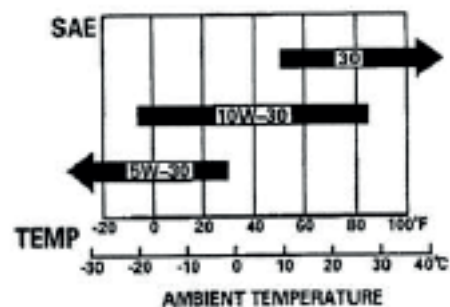

Use 4-stroke oil, or equivalent high detergent, premium quality motor oil certified to meet or exceed U.S. Automobile Manufacturer's requirements. Motor oils classified SG, SF/CC, CD will show this designation on the container.

SAE 10W 3D is recommended for general temperature use. Other viscosities shown in the chart may be used when the average temperature in your area is within the indicated range.

1. Remove the oil filler cap and wipe the dipstick clean.
2. Check the oil level by inserting the dipstick into the filler neck without screwing it in.
3. If the level is low, add the recommended oil to the upper mark on the dipstick.

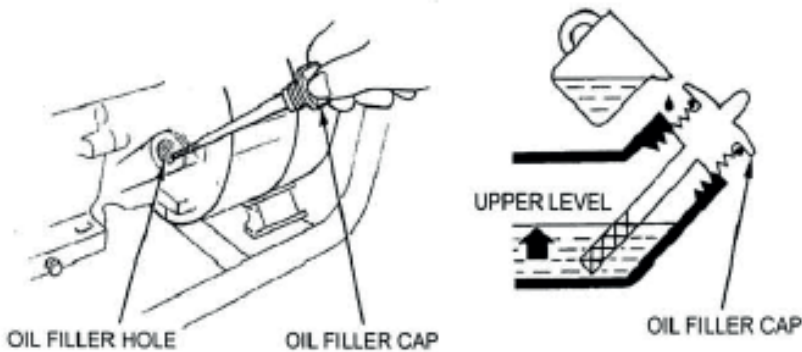

2) Fuel Recommendation

- 1- Check the fuel level gauge.
- 2- Refill the tank if the fuel level is low. Do not Fill above the shoulder of the fuel strainer.

WARNING!

- Gasoline is extremely flammable and is explosive under certain conditions.
- Refuel in a well-ventilated area with the engine stopped. Do not smoke or allow flames or sparks in the area where the engine is refueled or where gasoline is stored.
- Do not overfill the fuel tank (there should be no fuel in the filler neck). After refueling make sure the tank cap is closed properly and securely. Be careful not to spill fuel when refueling. Spilled fuel or fuel vapor may ignite. If any fuel is spilled, make sure the area is dry before starting the engine.
- Avoid repeated or prolonged contact with skin or breathing of vapor.
- KEEP OUT OF REACH OF CHILDREN

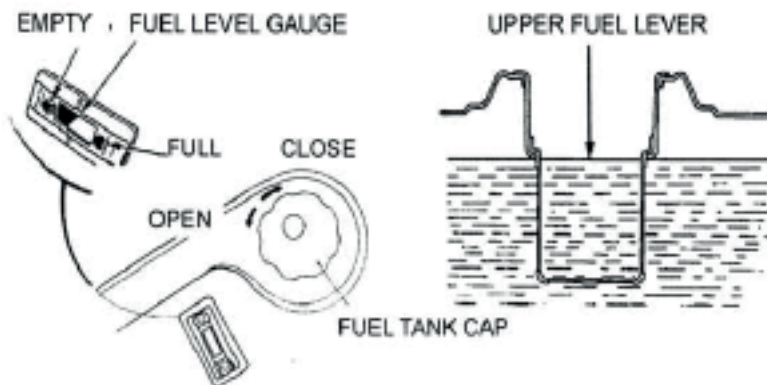

Use gasoline with a pump octane rating of 86 or higher.

We recommend unleaded gasoline because it produces fewer engine and spark plug deposits and extends exhaust system life.

Never use stale or contaminated gasoline or oil/gasoline mixture. Avoid getting dirt or water in the fuel tank.

Occasionally you may hear light 'spark knock' or "pinging" (metallic rapping noise) while operating under heavy loads. This is no cause for concern

if spark knock or pinging occurs at a steady engine speed. under normal load, change brands of gasoline. If spark knock or pinging persists, see an authorized generator dealer.

NOTICE!

Running the engine with persistent spark knock or pinging can cause engine damage.

Running the engine with persistent spark knock or pinging is misuse, and the Distributor's Limited Warranty does not cover parts damaged by misuse.

Oxygenated Fuels

Some gasoline are blended with alcohol or an ether compound to increase the octane. These gasoline are collectively referred to as oxygenated fuels. Some areas of the United States use oxygenated fuels to help meet clean air standards. If you use an oxygenated fuel, be sure its pump octane rating is 86 or higher.

Ethanol (ethyl or grain alcohol)

Gasoline containing more than 10% ethanol by volume may cause starting or performance problems. Gasoline containing ethanol may be marketed under the name "Gasohol".

Methanol (methyl or wood alcohol)

Gasoline containing methanol must contain cosolvents and corrosion inhibitors to protect the fuel system. Gasoline containing more than 5³/₄ methanol by volume may cause starting and/or performance problems and may damage metal, rubber and plastic parts of your fuel system.

MTBE (methyl tertiary butyl ether)

You MAY use gasoline containing up to 15% MTBE by Volume.

Before using an oxygenated fuel, try to confirm the fuel's contents. Some states (provinces in Canada) require this information to be posted on the pump. If you notice any undesirable operating symptoms, switch to a conventional unleaded gasoline. Fuel system damage or performance problems resulting from the USE Of an oxygenated fuel are not our responsibility and are not covered under warranty.

NOTICE!

Oxygenated fuels can damage paint and plastic. Be careful not to spill fuel when filling your fuel tank. Damage caused by spilled fuel is not covered under warranty.

6. STARTING/STOPPING THE ENGINE**Starting the engine**

- ①. Make sure that AC circuit breaker IS IN THE OFF position.
The generator may be hard to start if a load is connected.
- ②. Turn the fuel valve to the- ON position
- ③. Turn the choke lever or to the CLOSE position, or pull the choke rod out to the CLOSE position.
- ④. start the engine

With recoil starter:

- Turn the engine switch to the ON position.
- Pull the starter grip until compression is felt, then pull briskly.

NOTICE!

Do not allow the starter grip to snap back against the engine.

Return, fit gently to prevent damage to the or housing.

With electric starter (Optional kit)

- Turn the engine switch to the START position and hold it there for 5 seconds or until the engine starts.

NOTICE!

Operating starter motor for more than 5 seconds, can damage the motor. If the engine fails to start, release the switch and wait 10 seconds before operating the starter again. If the speed of the starter motor drops after a period of time, it indicates that the battery should be recharged.

When the engine starts, allow the engine switch to return to the ON position.

⑤. Turn the choke Lever or push the choke rod to the OPEN position as the engine warms up.

Stopping the engine

In an emergency:

To stop the engine in an emergency, move the engine switch to the OFF position.

In normal use:

- ①. Turn the AC circuit breaker to the OFF position.
Disconnect the DC battery charging cables.
- ②. Turn the engine switch to the OFF position.
- ③. Turn the fuel valve to the OFF position.

7. MAINTENANCE

Good maintenance is essential for safe, economical, and trouble-free operation. It will also help reduce air pollution.

WARNING!

Exhaust gas contains poisonous carbon monoxide, Shut off the engine before performing any maintenance, If the engine must be run, make sure the area is well ventilated.

Periodic maintenance and adjustment is necessary to keep the generator in good operating condition. Perform the service and inspection at the intervals shown in the Maintenance schedule below.

1) MAINTENANCE SCHEDULE

REGULAR SERVICE PERIOD		Each use	First month or 20 Hrs	Every 3 months or 50 Hrs.	Every 6 months or 100 Hrs.	Every year or 300 Hrs
Performed at every indicated month or operating hour interval whichever comes first						
ITEM						
Engine Oil	Check level	O				
	Change		O		O	
Air cleaner	Check	O				
	Clean			0(1)		
Sediment Cup	Clean				O	
Spark plug	Check.-Clean				O	
Spark arrester (optional parts)	Clean				O	
Valve Cleaner	Check-Adjust					O(2)
Fuel tank and strainer	Clean					O(2)
Fuel line	Check	Every 2 years (replace if necessary (2))				

- (1). Service- more frequently when used in dusty areas.
- (2). These items should be serviced by an authorized generator dealer, unless the owner has the proper tools and is mechanically proficient.
- (3). For professional commercial use, long hours of operation to determine proper maintenance intervals

WARNING!

Improper maintenance, or failure to correct a problem before operation, can cause a malfunction in which you can be Seriously hurt or killed. Always follow the- inspection and maintenance recommendations and schedules in this owner's manual.

The maintenance schedule applies to normal operating conditions. If you operate your generator under severe conditions, Such as sustained high-load or hig1i-lerinp0rature operation, or use it in unusually wet or dusty conditions, consult your servicing dealer for recommendsticin3applicable to your individual need3 and use.

2) Tool kit

The tools supplied with the generator will help you to perform the owner maintenance procedures listed on the following page. Always keep (his tool kit with the generator.

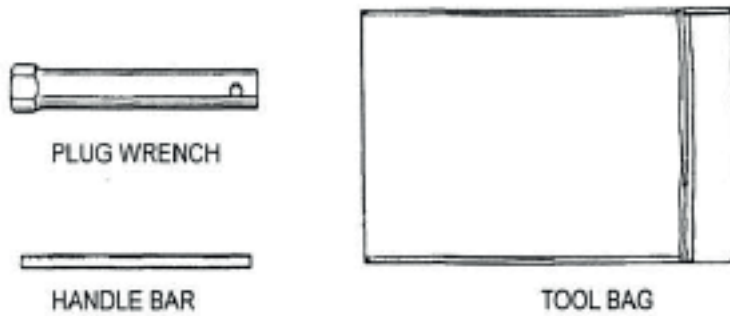

NOTE!

Diagrams may vary according to the types.

3) Engine oil change

Drain the oil while the engine is warm to assure complete and rapid draining.

1. Remove the drain plug and sealing washer, oil filler cap, and drain the oil.
2. Reinstall the drain plug and sealing washer. Tighten the plug securely.
3. Refill with the recommended oil and check the oil level.

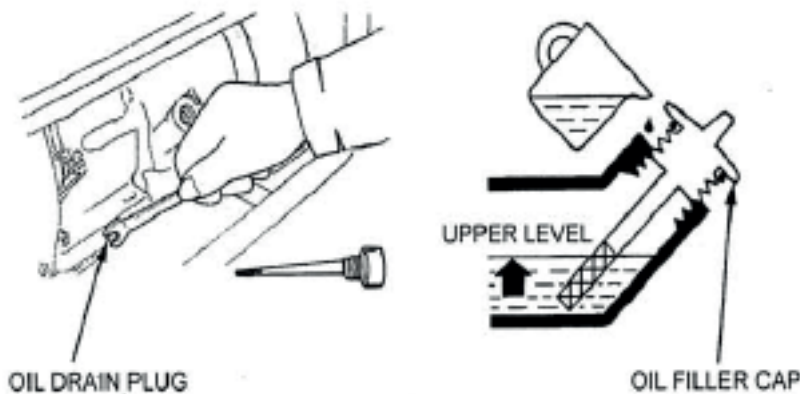

CAUTION!

Used motor oil may cause skin cancer if repeatedly left in contact with the skin for prolonged periods. Although this is unlikely unless you handle used oil on a daily basis, it is still advisable to thoroughly wash your hands with soap and water as soon as possible after handling used oil.

Please dispose of used motor oil in a manner that is compatible with the environment.

We suggest you take it in a sealed container to your local service station or recycling center for reclamation.. Do not throw it in the trash or pour it on the ground.

4) Air cleaner service

A dirty air cleaner will restrict air flow to the carburetor. To prevent carburetor malfunction service the air cleaner regularly. Service more frequently when operating the generator in extremely dusty areas.

WARNING!

Using gasoline or flammable solvent to clean the filter element can cause a fire or explosion. Use only soapy water or nonflammable solvent.

NOTICE!

Never run the generator without the air cleaner. Rapid engine wear will result.

- ①. Unsnap the air cleaner cover dips, remove the air cleaner cover, and remove the- element.
- ②. Wash the element in a solution of household detergent; and warm water, then rinse thoroughly; or wash in nonflammable or high flash point solvent. Allow element to dry thoroughly.
- ③. Soak the element in clean engine oil and squeeze out the excess oil. The engine will smote during initial start-up if too much oil is left in the element.
- ④. Reinstall the air cleaner element and the cover

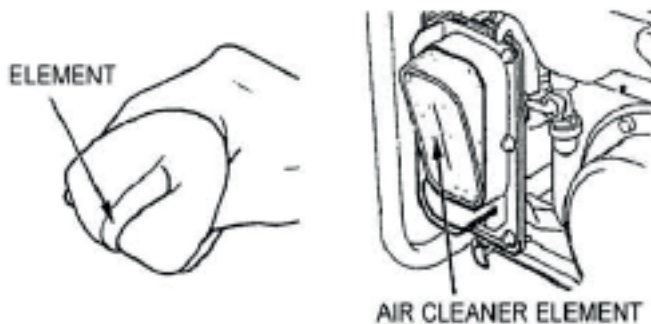

5) Fuel Sediment Cup Cleaning

The sediment cup prevents dirt water which may be in the fuel tank from entering the carburetor. If the engine has not been run for a long time, the sediment -cup should be cleaned.

- ①. turn the fuel valve to the OFF position
Remove the sediment cup, and o-ring.
- ②. Clean the sediment cup. and o-ring. In nonflammable or high flash point solvent.
- ③. Reinstall o-ring, and sediment cup.
- ④. Turn the fuel valve ON and check for leaks

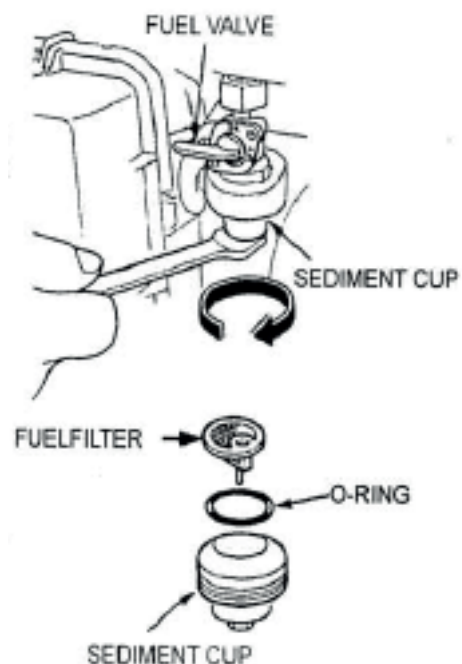

6) Spark Plug Service sediment cup

Recommended spark plugs: F5T or F6TC or F7TJC or T or other equivalents

To ensure proper engine operation, the Spark plug must be properly gapped and free of Deposits.

If the engine has been running, the muffler will be very hot. Be careful not to touch the muffler.

- ①. Remove the spark plug cap.
- ②. Clean any dirt from around the spark plug base.
- ③. Use the wrench supplied in the tool kit to remove the spark plug.
- ④. Visually inspect the spark plug. Discard it if the insulator is cracked or chipped. Clean the spark plug with a wire brush if it is to be reused.

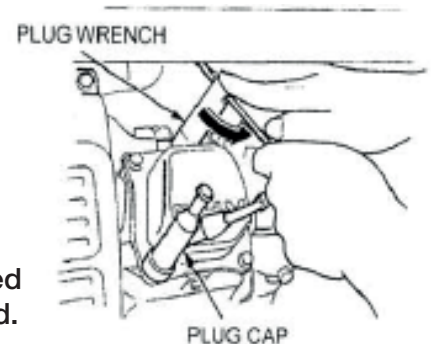

- ⑤. Measure the plug gap with a feeler gauge. Correct as necessary by carefully bending side electrode.

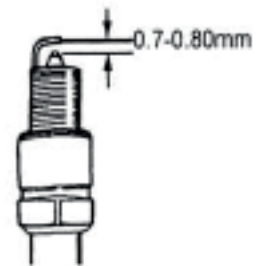

The gap should be: 0.70-0.80 mm {0.026-0.031 in}.

- ⑥. Check that the spark plug washer is in good condition, and thread the spark plug in by hand to prevent cross-threading.
- ⑦. After the spark plug is seated. Tighten with a spark plug wrench to compress the Washer. If installing a new spark plug, tighten 1/2 turn after the spark plug seats to compress the washer. If reinstalling a used spark plug, tighten 1/8 - 1/4 turn after the spark plug seats to compress the washer.

NOTICE!

The spark plug must be securely tightened. An improperly tightened spark plug can become very hot and could damage the engine. Never use spark plugs which have an improper heat range, use only the recommended spark plugs or equivalent.

8. TRANSPORTING/STORAGE

When transporting the generator, turn the engine switch and the fuel valve OFF. Keep the generator level to prevent fuel spillage. Fuel vapor or spilled fuel may ignite.

WARNING!

Contact with a hot engine or exhaust system can cause serious burns- or fires. Let the engine cool before transporting or storing the generator,

Take care- not to drop or strike the generator when transporting. Do not place heavy objects on the generator.

Before storing the unit for an extended period:

- Be sure the storage area is free of excessive humidity and dust.
- Service according to the table below

STORAGE TIME	RECOMMENDED SERVICE PROCEDURE TO PREVENT HARD STARTING
Less than 1 month 1 to 2 months	No preparation required Fill with fresh gasoline and add gasoline- conditioner
2 months to 1 year	Fill with fresh gasoline and add gasoline conditioner drain the carburetor float bowl Drain the fuel sediment cup
1 year or more	Fill will: fresh gasoline and add gasoline conditioner* Drain the carburetor float bowl Drain the fuel* sediment cup Remove the spark plug. Put a tablespoon of engine oil into the cylinder. Turn the engine slowly with the pull rope to distribute the oil Reinstall the spark plug Change the engine oil After removal from storage-, drain the stored gasoline into 3 suitable
*Use gasoline conditioners that are formulated to extend storage life Contact your authorized generator dealer for conditioner recommendations	

- ①. Drain the carburetor by loosening the drain screw. Drain the gasoline into a suitable container.

WARNING!

Gasoline is extremely flammable and is explosive under certain conditions. Perform this task in a well ventilated area with the engine stopped. Do not smoke or allow flames or sparks in the area during this procedure.

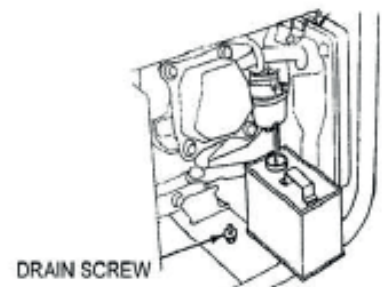

- ②. Change the engine oil.
- ③. Remove the spark plug, and pour about a tablespoon of clean engine oil into the cylinder. Crank the engine several revolutions to distribute the oil, then reinstall the spark plug.
- ④. Slowly pull the starter grip until resistance is felt. At this point, the piston is coming up on its compression stroke and both intake and exhaust valves are closed. Storing the engine in this position will help to protect it from internal corrosion.



Align the notch on the starter pulley with the hole at the top of recoil starter.

9. TROUBLESHOOTING

when the engine Mill not start:

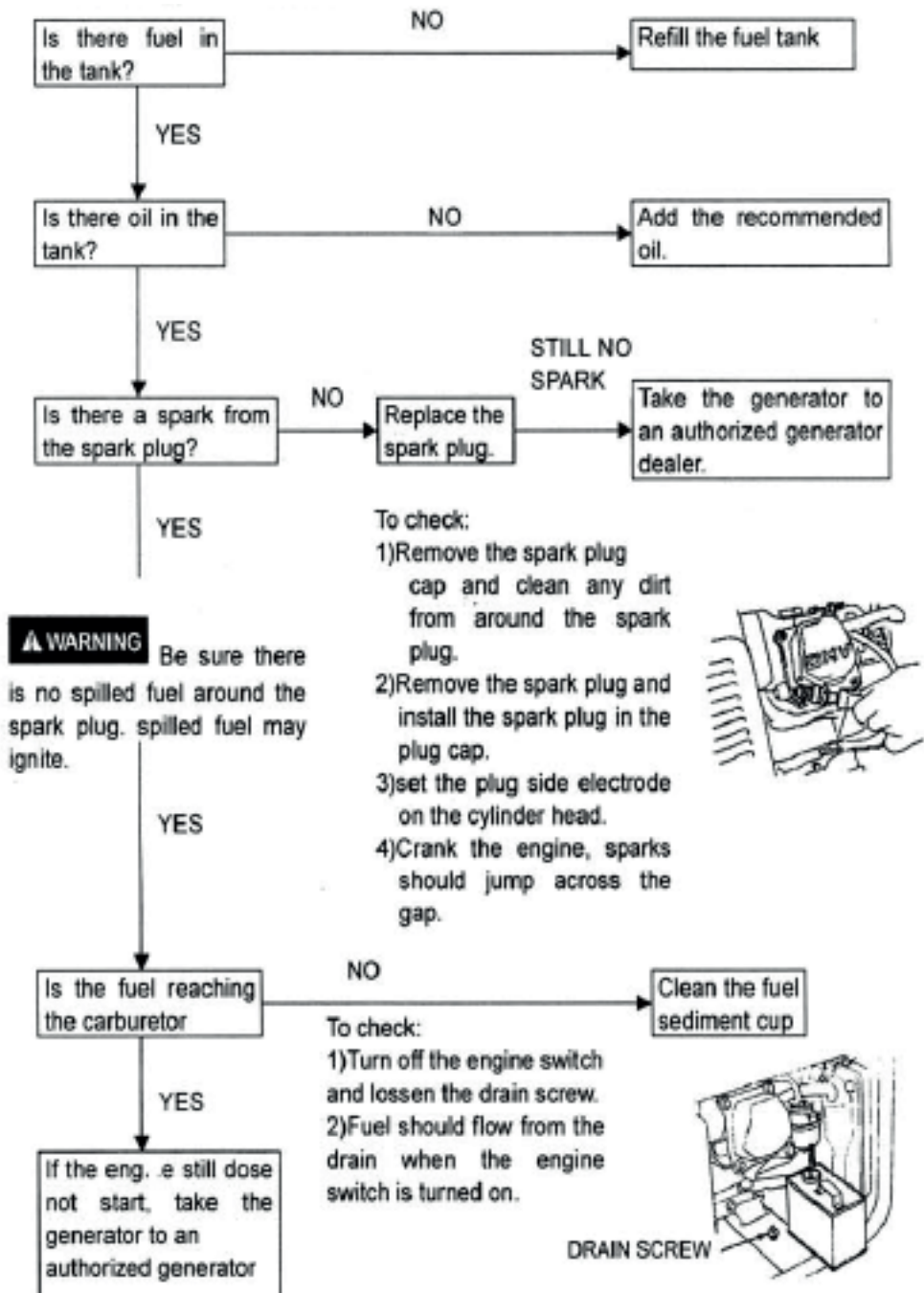

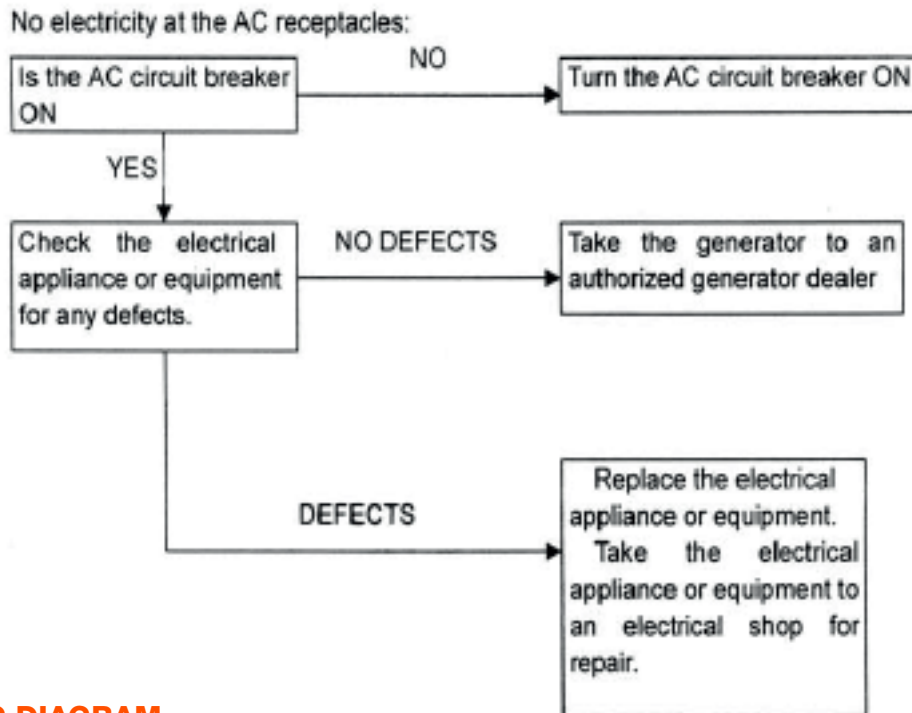

10. WINING DIAGRAM

1) 2~2.5KW Manual generator diagram

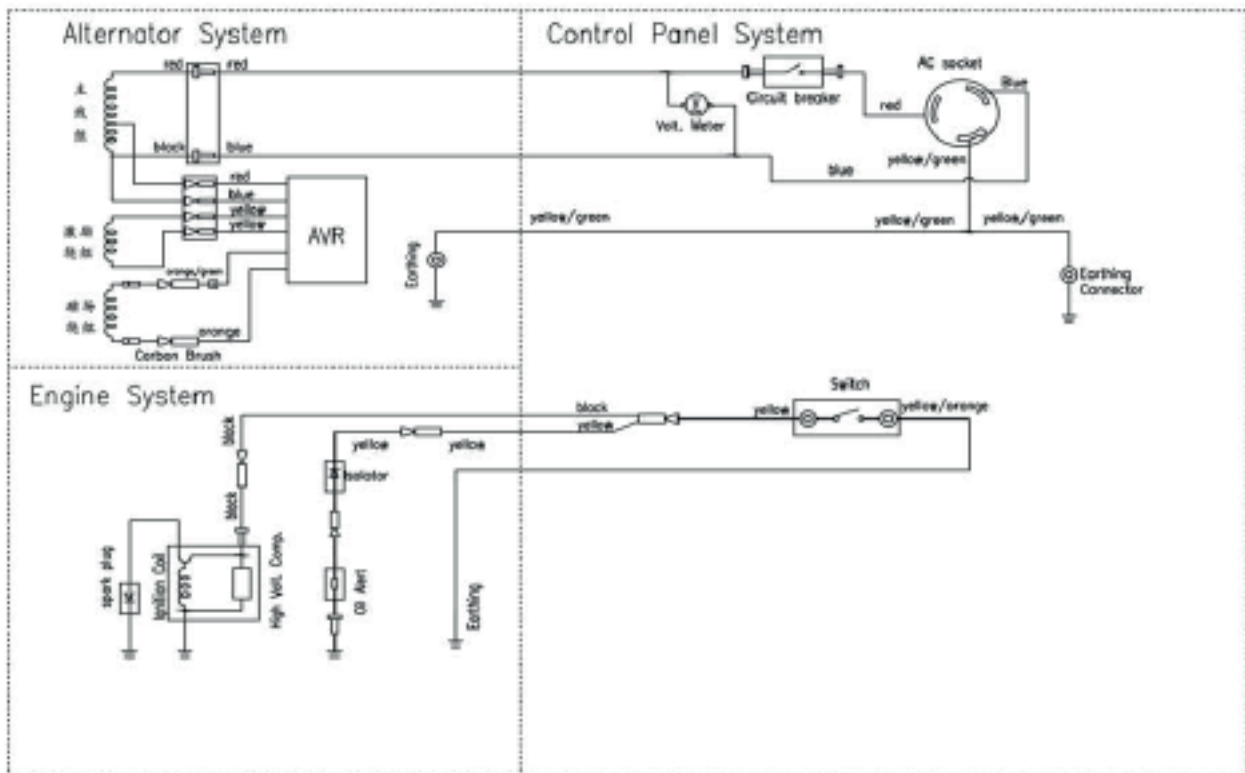

2) 2~2.5KW Key start generator diagram

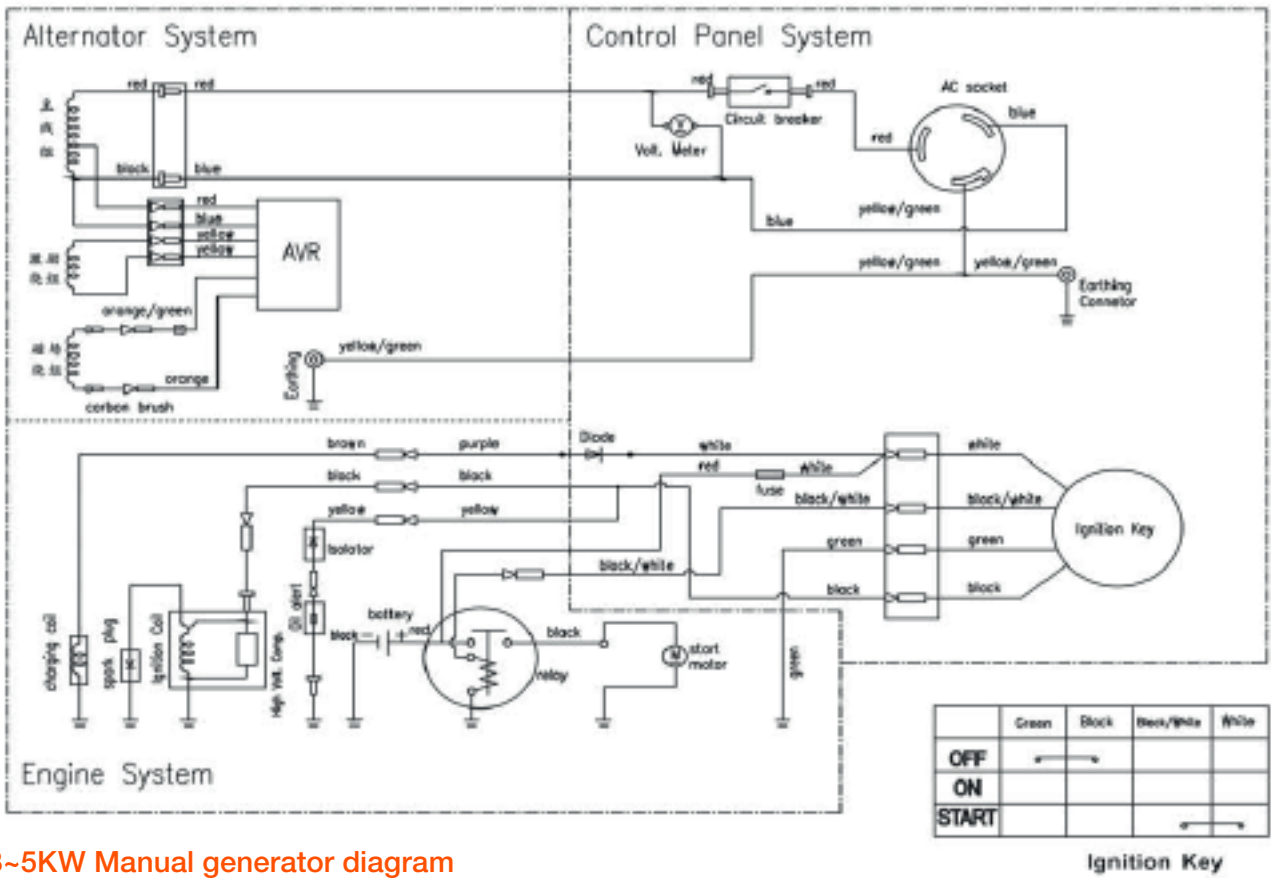

3) 3~5KW Manual generator diagram

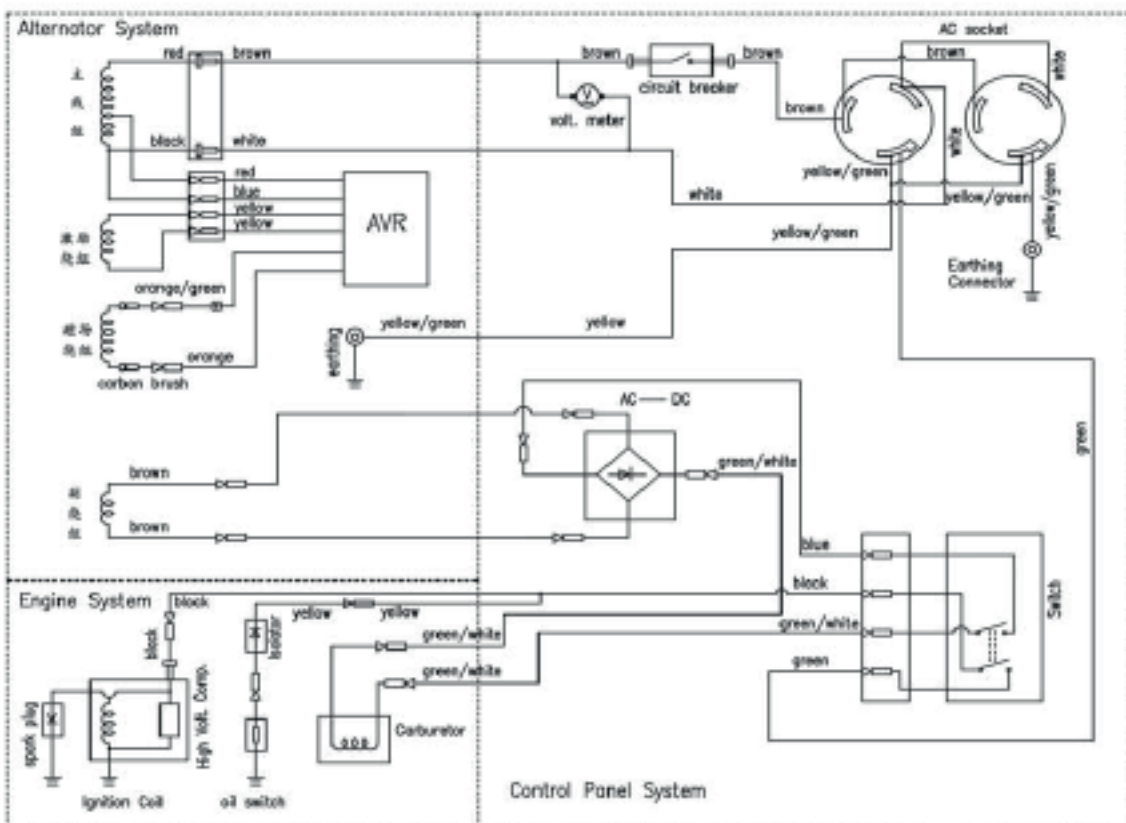

4)3~5KW Key start generator diagram

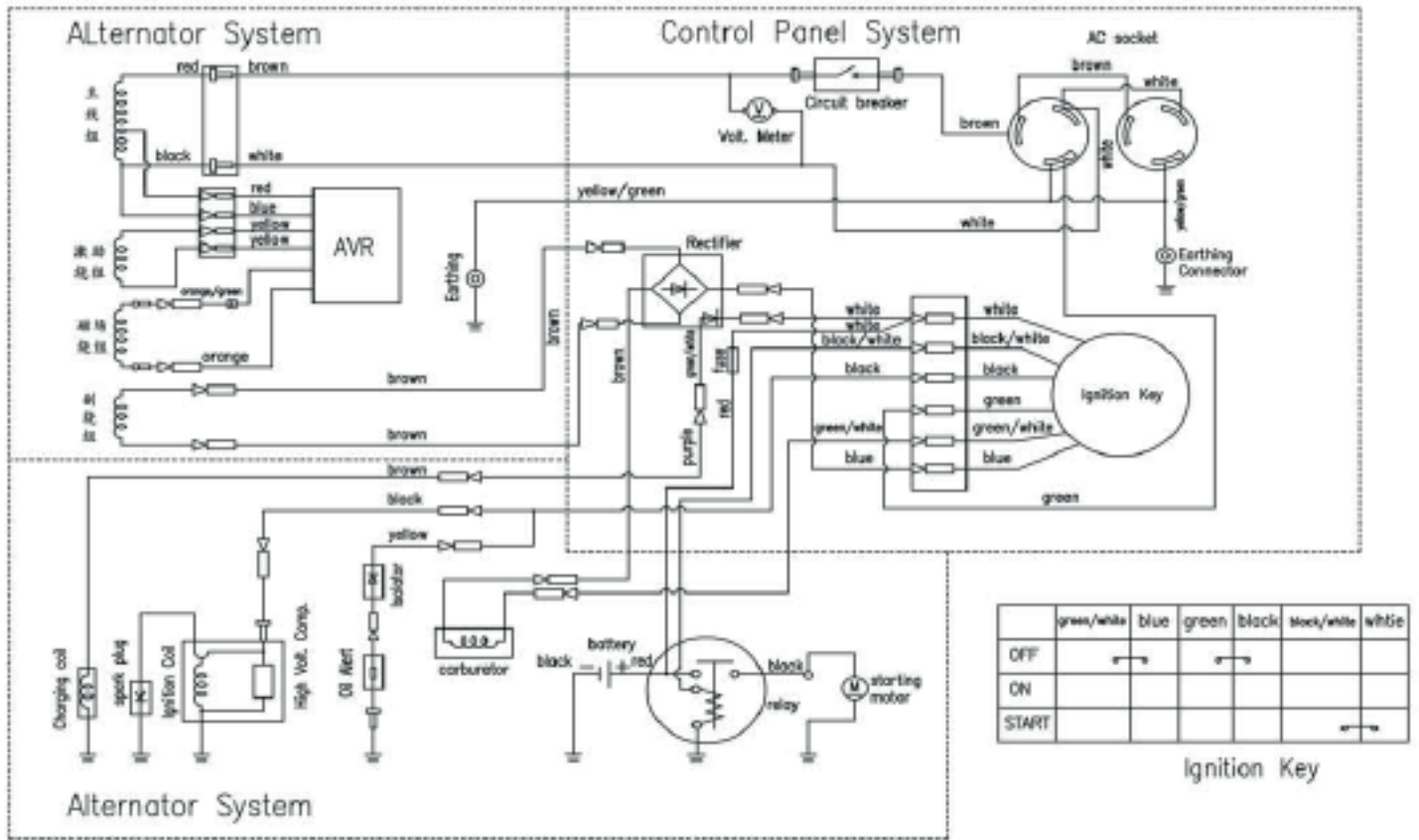

11. SPECIFICATIONS

GD1000

PERFORMANCE

Rated Power: 850 W

Max Power: 1000 W

ENGINE

Displacement: 93.5 cc

Starting system: Recoil

Oil tank capacity: 0.37 L

Low oil sensor: yes

ALTERNATOR

Volt. Reg. System: AVR

Insulation class: F

Rotor winding material (Cu/Al): Al

Stator winding material (Cu/Al): Al

Phase: Single

FUEL TANK

Fuel tank capacity: 6 L

PORTABILITY KIT

Frame tubing size: 19 mm

Wheel/Handle: no

ACCESSORIES

Spark plug wrench: yes

GD2500

PERFORMANCE

Rated Power: 2000 W (Cu) / 1800 W (Alu)

Max Power: 2200 W (Cu) / 2000 W (Alu)

ENGINE

Displacement: 196 cc

Starting system: Recoil

Oil tank capacity: 0.6 L

Low oil sensor: yes

ALTERNATOR

Volt. Reg. System: AVR

Insulation class: F

Rotor winding material (Cu/Al): Cu/Alu

Stator winding material (Cu/Al): Cu/Alu

Phase: Single

FUEL TANK

Fuel tank capacity: 15 L

PORTABILITY KIT

Frame tubing size: 28 mm

Wheel/Handle: yes

ACCESSORIES

Spark plug wrench: yes

GD3500

PERFORMANCE

Rated Power: 2500 W (Cu) / 2300 W (Alu)

Max Power: 2800 W (Cu) / 2600 W (Alu)

ENGINE

Displacement: 208 cc

Starting system: Recoil

Oil tank capacity: 0.6 L

Low oil sensor: yes

ALTERNATOR

Volt. Reg. System: AVR

Insulation class: F

Rotor winding material (Cu/Al): Cu/Alu

Stator winding material (Cu/Al): Cu/Alu

Phase: Single

FUEL TANK

Fuel tank capacity: 15 L

PORTABILITY KIT

Frame tubing size: 28 mm

Wheel/Handle: yes

ACCESSORIES

Spark plug wrench: yes

GD3500E

PERFORMANCE

Rated Power: 2500 W (Cu) / 2300 W (Alu)

Max Power: 2800 W (Cu) / 2600 W (Alu)

ENGINE

Displacement: 208 cc

Starting system: Electric

Oil tank capacity: 0.6 L

Low oil sensor: yes

ALTERNATOR

Volt. Reg. System: AVR

Insulation class: F

Rotor winding material (Cu/Al): Cu/Alu

Stator winding material (Cu/Al): Cu/Alu

Phase: Single

FUEL TANK

Fuel tank capacity: 15 L

PORTABILITY KIT

Frame tubing size: 28 mm

Wheel/Handle: yes

ACCESSORIES

Spark plug wrench: yes

GD6500

PERFORMANCE

Rated Power: 5000 W

Max Power: 5500 W

ENGINE

Displacement: 389 cc

Starting system: Recoil

Oil tank capacity: 1.1 L

Low oil sensor: yes

ALTERNATOR

Volt. Reg. System: AVR

Insulation class: B

Rotor winding material (Cu/Al): Cu

Stator winding material (Cu/Al): Cu

Phase: Single

FUEL TANK

Fuel tank capacity: 25 L

PORTABILITY KIT

Frame tubing size: 28 mm

Wheel/Handle: yes

ACCESSORIES

Spark plug wrench: yes

GD6500E

PERFORMANCE
Rated Power: 5000 W
Max Power: 5500 W

ENGINE

Displacement: 389 cc
Starting system: Electric
Oil tank capacity: 1.1 L
Low oil sensor: yes

ALTERNATOR

Volt. Reg. System: AVR
Insulation class: B
Rotor winding material (Cu/Al): Cu
Stator winding material (Cu/Al): Cu
Phase: Single

FUEL TANK

Fuel tank capacity: 25 L

PORTABILITY KIT

Frame tubing size: 28 mm
Wheel/Handle: yes

ACCESSORIES

Spark plug wrench: yes

GD7000

PERFORMANCE
Rated Power: 6000 W
Max Power: 6500 W

ENGINE

Displacement: 420 cc
Starting system: Recoil
Oil tank capacity: 1.1 L
Low oil sensor: yes

ALTERNATOR

Volt. Reg. System: AVR
Insulation class: Stator B/Rotor F
Rotor winding material (Cu/Al): Cu
Stator winding material (Cu/Al): Cu
Phase: Single

FUEL TANK

Fuel tank capacity: 25 L

PORTABILITY KIT

Frame tubing size: 28 mm
Wheel/Handle: yes

ACCESSORIES

Spark plug wrench: yes

GD7000E

PERFORMANCE
Rated Power: 6000 W
Max Power: 6500 W

ENGINE

Displacement: 420 cc
Starting system: Recoil/Electric
Oil tank capacity: 1.1 L
Low oil sensor: yes

ALTERNATOR

Volt. Reg. System: AVR

Insulation class: Stator B/Rotor F
Rotor winding material (Cu/Al): Cu
Stator winding material (Cu/Al): Cu
Phase: Single

FUEL TANK

Fuel tank capacity: 25 L

PORTABILITY KIT

Frame tubing size: 28 mm
Wheel/Handle: yes

ACCESSORIES

Spark plug wrench: yes

GD8500

PERFORMANCE
Rated Power: 7000 W
Max Power: 7500 W

ENGINE

Displacement: 439 cc
Starting system: Recoil
Oil tank capacity: 1.1 L
Low oil sensor: yes

ALTERNATOR

Volt. Reg. System: AVR
Insulation class: Stator B/Rotor F
Rotor winding material (Cu/Al): Cu
Stator winding material (Cu/Al): Cu
Phase: Single

FUEL TANK

Fuel tank capacity: 25 L

PORTABILITY KIT

Frame tubing size: 28 mm
Wheel/Handle: yes

ACCESSORIES

Spark plug wrench: yes

GD8500E

PERFORMANCE
Rated Power: 7000 W
Max Power: 7500 W

ENGINE

Displacement: 439 cc
Starting system: Recoil/Electric
Oil tank capacity: 1.1 L
Low oil sensor: yes

ALTERNATOR

Volt. Reg. System: AVR
Insulation class: Stator B/Rotor F
Rotor winding material (Cu/Al): Cu
Stator winding material (Cu/Al): Cu
Phase: Single

FUEL TANK

Fuel tank capacity: 25 L

PORTABILITY KIT

Frame tubing size: 28 mm
Wheel/Handle: yes

ACCESSORIES

Spark plug wrench: yes

GD12000E

PERFORMANCE

Rated Power: 8500 W

Max Power: 9500 W

ENGINE

Displacement: 688 cc

Starting system: 12 V Electric

Oil tank capacity: 1.1 L

Low oil sensor: yes

ALTERNATOR

Volt. Reg. System: AVR

Insulation class: F

Rotor winding material (Cu/Al): Cu

Stator winding material (Cu/Al): Cu

Phase: Single

FUEL TANK

Fuel tank capacity: 25 L

PORTABILITY KIT

Frame tubing size: 32 mm

Wheel/Handle: yes

ACCESSORIES

Spark plug wrench: yes

GD12000E-3

PERFORMANCE

Rated Power: 9500 W

Max Power: 10500 W

ENGINE

Displacement: 688 cc

Starting system: 12 V Electric

Oil tank capacity: 1.1 L

Low oil sensor: yes

ALTERNATOR

Volt. Reg. System: AVR

Insulation class: F

Rotor winding material (Cu/Al): Cu

Stator winding material (Cu/Al): Cu

Phase: Single

FUEL TANK

Fuel tank capacity: 25 L

PORTABILITY KIT

Frame tubing size: 32 mm

Wheel/Handle: yes

ACCESSORIES

Spark plug wrench: yes

12. GENERATOR ASSEMBLY AND MOUNTING

If your generator is supplied with a wheel kit, please follow the instructions below

1. Place the bottom of the generator cradle on a flat, even surface. Temporarily place unit on blocks to ease assembly.
2. Slide axle through both mounting braces on the cradle frame as shown(Fig 1)
3. Slide a wheel (with the inflation valve facing out)and a flat washer over the axle, then secure the wheel with a retaining pin(Fig 2.Fig 3.Fig 4)
4. Install the other wheel in the same manner
5. Secure each vibration mount to the support leg with a lock nut, and a cap screw (Fig 5):
6. Secure the support leg to the cradle cap screws and lock nuts (Fig 6):
7. Position the handles on the cradle, cap screws and lock nuts (Fig 7.Fig 8.Fig 9)
8. Check that all fasteners are tight and tires are inflated between 15-40 PSI



(Fig 1)

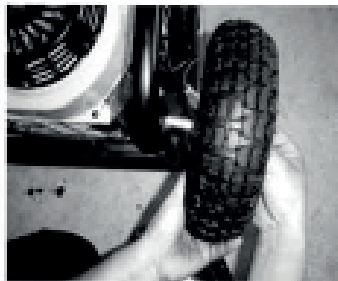

(Fig 2)

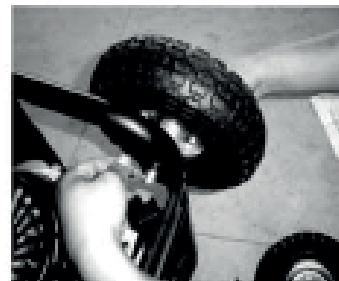

(Fig 3)



(Fig 4)

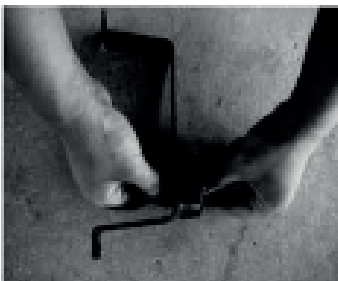

(Fig 5)



(Fig 6)

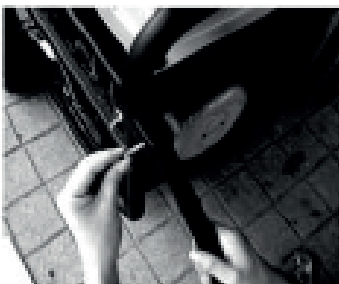

(Fig 7)



(Fig 8)

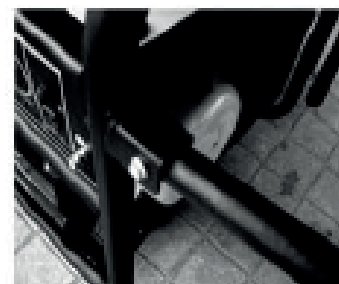

(Fig 9)



DAEWOO
POWER PRODUCTS

www.daewoopowerproducts.com

Manufactured under license of Daewoo International Corporation, Korea